

HL0714 RHS HL0713 LHS

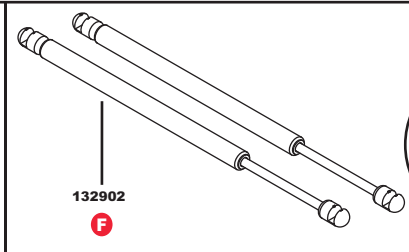

132902 F



EZUp Instruction kit Mercedes EZUp Hoodlift HL0710

1 OPEN HOOD OF VEHICLE USING ROD TO KEEP HOOD OPEN WHILST YOU WORK

The LHS is determined when Driver is sitting in the Vehicle

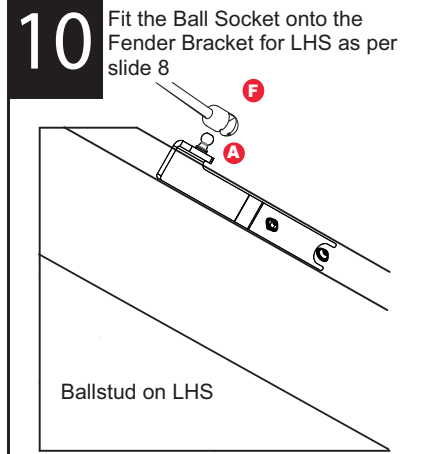
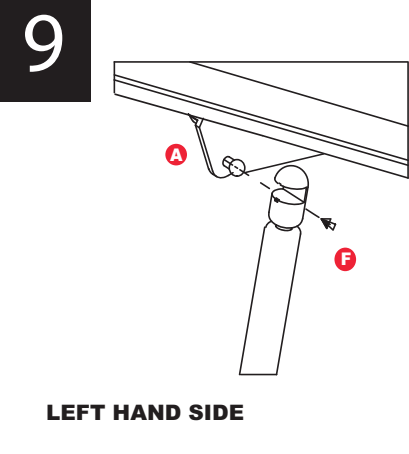
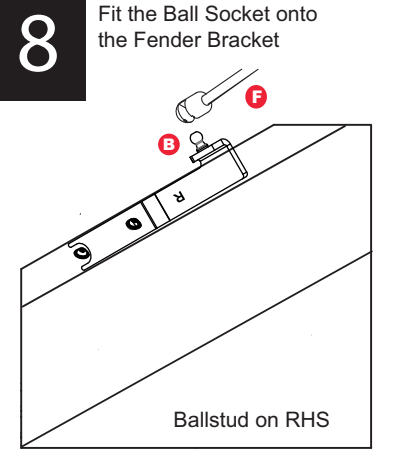
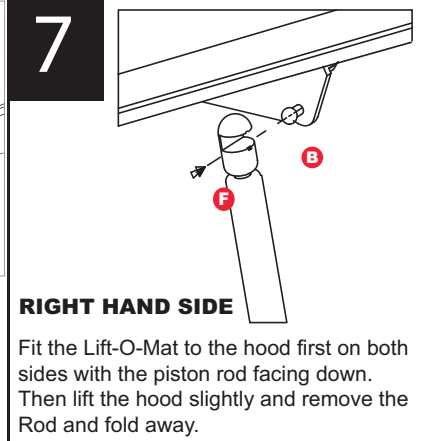
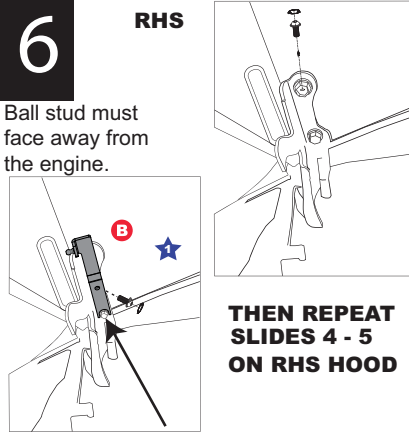
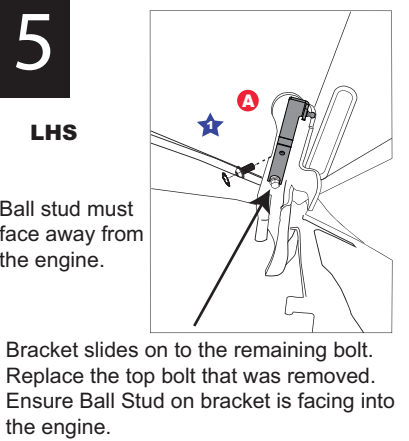
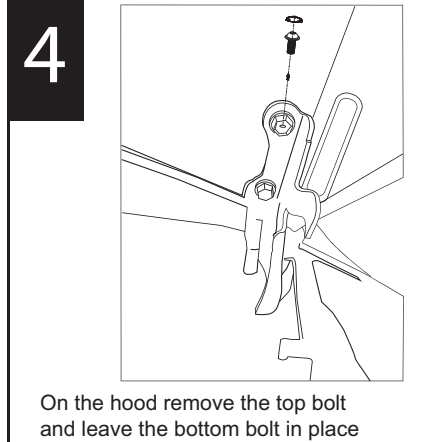
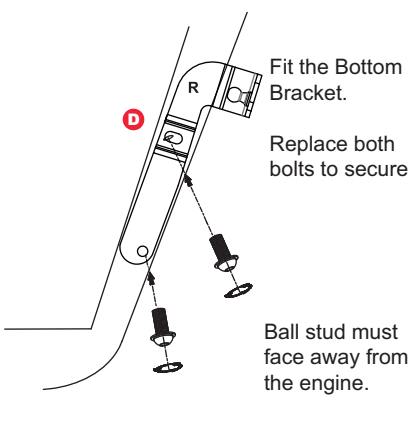
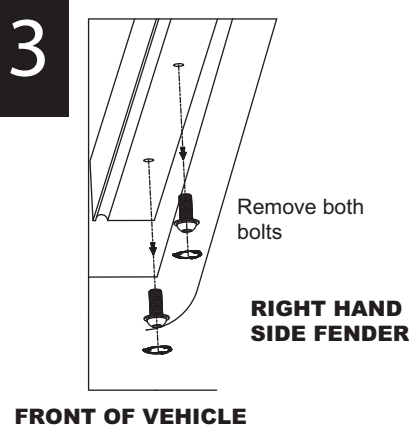
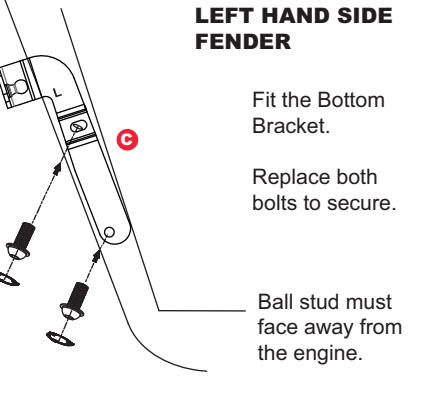
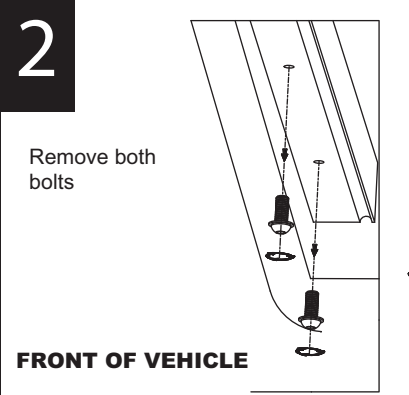

NB: After installation open Hood/Bonnet gently to ensure that there is no interference with any hardware.

| FITTING KIT CODE | MANUFACTURER | MODEL TYPE | YEAR | PRODUCT | REVISION | LABOUR TIME | DATE | PAGE |
|------------------|----------------|------------|----------------|---------|----------|-------------|------------|------|
| HL0710 | MERCEDES | X-CLASS | 2016 2ND INTRO | EZUp | 2 | 30min | 04/07/2018 | 1 |
| TORQUE-N.m | ★ 25N.m ± 2N.m | | | | | | | |

IMPORTANT: No liability will be incurred by Industrial Specialised Applications company, for injury, death, or property damage caused by a product which has been set up, operated, and/or installed contrary to EZUp installation guide/ manual, or which has been subjected to misuse, negligence, or accident, or which has been repaired or altered by anyone other than Industrial Specialised Applications, or which has been used in a manner or for a purpose for which the product was not designed.