

# CONTENTS

<b>1</b>	<b>PREMISE</b> .....	<b>65</b>
<b>2</b>	<b>DESCRIPTION</b> .....	<b>66</b>
2.1	Intended Use .....	66
2.2	Kit content list .....	66
2.3	Principal specifications.....	67
<b>3</b>	<b>INSTALLATION</b> .....	<b>68</b>
3.1	Installation on Konfort units .....	68
3.2	Flushing program activation .....	69
3.3	Setup of flushing timing .....	70
3.4	Flushing program deactivation.....	72
<b>4</b>	<b>SAFETY</b> .....	<b>74</b>
4.1	General Safety Rules.....	74
4.2	Guidelines for Handling Refrigerants.....	75
4.2.1	Glossary of Terms .....	75
4.2.2	Precautions for refrigerant storage .....	75
4.2.3	Conditions of the refrigerant and the system.....	75
4.2.4	Recycling Capacity .....	75
4.2.5	General Notions .....	76
4.3	Safety Devices .....	76
4.4	The Work Environment.....	76
<b>5</b>	<b>INTRODUCTION TO FLUSHING WITH REFRIGERANT</b> .....	<b>77</b>
5.1	What is Flushing? .....	77
5.2	Why Flushing is important?.....	77
5.3	When do you flush the A/C system? .....	78
5.4	Examples of system contamination .....	78
5.5	Components sensible to contamination .....	79
<b>6</b>	<b>FLUSHING METHOD WITH ACKF01 KIT</b> .....	<b>81</b>
6.1	Preliminary measures.....	81
6.2	Konfort unit preparation for flushing.....	83
6.3	Installation of bridges and adapters .....	85
6.4	Examples of adaptors and connections for flushing .....	87
6.5	Flushing systems with expansion valve.....	90
6.5.1	Flushing the evaporator side.....	90
6.5.2	Back-flushing the evaporator side.....	91
6.5.3	Flushing the condenser side.....	92
6.5.4	Back-flushing the condenser side .....	93
6.6	Flushing systems with orifice tube.....	94
6.6.1	Flushing the evaporator side.....	94
6.6.2	Back-flushing the evaporator side.....	95
6.6.3	Flushing the accumulator-compressor junction .....	96
6.6.4	Back-flushing the accumulator-compressor junction .....	97
6.6.5	Flushing the condenser side.....	98
6.6.6	Back-flushing the condenser side .....	99
6.7	Monitoring flushing process.....	100

6.8	After-flushing recommendations .....	101
<b>7</b>	<b>OPERATING FLUSHING PROGRAM .....</b>	<b>102</b>
7.1	Regular functions of the A/C service station.....	102
7.2	A/C service station preparation.....	102
7.3	Start-up.....	102
7.4	Stoppage .....	103
7.5	Emergency stop .....	103
7.6	Pressurizing the A/C service station (Only for Konfort 600E series) .....	103
7.6.1	Pressurizing Konfort ECK 605E, 610E, 610E BUS, 650 .....	103
7.6.2	Pressurizing Konfort ECK 670E.....	105
7.7	Flushing cycle Konfort ECK605E / 610E / 610E BUS / 650E.....	107
7.8	Flushing cycle Konfort ECK670E.....	112
7.9	Messages .....	116
<b>8</b>	<b>MAINTENANCE.....</b>	<b>118</b>
8.1	Standard maintenance .....	118
8.1.1	Konfort units standard maintenance .....	118
8.1.2	Flushing canister filter cleaning / replacement.....	118
8.1.3	Flushing canister internal cleaning .....	119
8.2	Periodical operations.....	119
8.3	Safety operations .....	119
8.4	Calibration.....	120
<b>9</b>	<b>PARTS LIST &amp; ILLUSTRATIONS.....</b>	<b>121</b>

# 1 PREMISE

The kit **ACKF01** has been designed and built to ensure long lasting, high-level operating reliability with maximum safety for user; to this end, TEXA has performed rigid tests and selected better materials and components (combined with the adoption of ample safety coefficients). Moreover, the production management guarantees a product free of damage or malfunctions.

A further, definitive guarantee is ensured by the rigid factory test and inspection carried out on the unit.

**The user needs only to be responsible for the proper use of the unit in accordance with the instructions found in this manual.**

It is essential that this kit is used according to the intended use specified in this manual, TEXA S.p.A. cannot be held responsible for damage to persons, animals and/or objects due to improper use different to that illustrated in this instruction manual.

TEXA S.p.A. reserves the right to make technical and aesthetic alterations to the product without prior notification.

This unit is designed for use in commercial environments and light industry.

The purpose of this manual is:

- A) to supply the user with all the information needed to use the kit starting from purchase on through to the disposal of this same unit.
- B) to ensure maximum support for the personnel assigned to the use and the maintenance of the kit. However, for any special needs or requests for technical assistance or spare parts, please contact TEXA S.p.A.

This manual may contain printing mistakes.

## **TEXA S.p.A.**

Via I° Maggio, 9

30150 Monastier di Treviso (TV) ITALY

Tel. +39 0422 791311

Fax +39 0422 791300

[www.texa.it](http://www.texa.it)

© **copyright and database rights 2005-2007**. This material is protected by copyright and database rights. All rights reserved under national law and international conventions.

## 2 DESCRIPTION

### 2.1 Intended Use

ACKF01 is an optional kit to be installed on Texa Konfort service stations model ACK605E, ACK610E, ACK610E BUS, ACK650 and ACK670.

It requires various components included in the kit and the activation of the flushing function from the software of the listed service stations.

The objective is to use R134a liquid refrigerant contained in the tank of the A/C service station as flushing agent for removing lubricant, UV tracer and loose debris from the A/C system when it is possible.

**ACKF01 flushing kit is suitable for personal cars, vans, cabin of trucks.**

**ACKF01 flushing kit is not suitable for buses or industrial refrigeration systems.**

### 2.2 Kit content list

ACKF01 flushing kit is shown in the following pictures.

The components are identified by the numbers reported in the table.



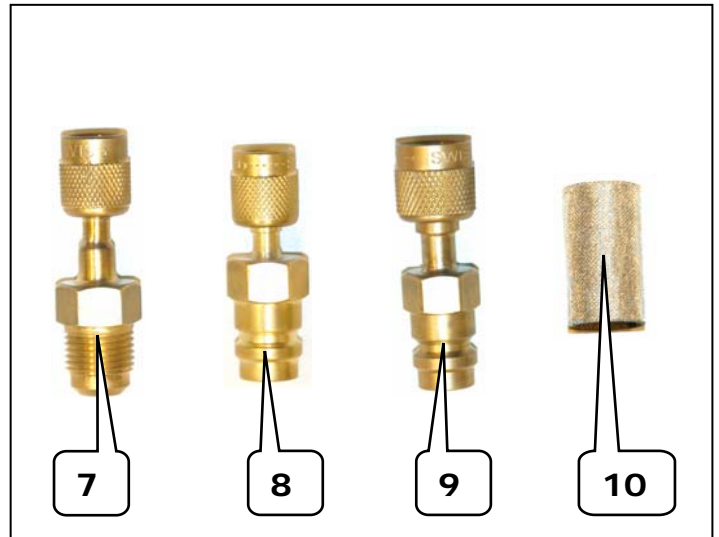
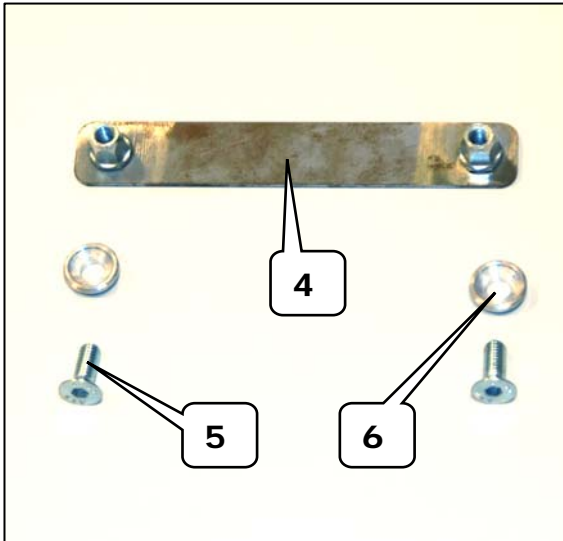

Pos.	Part	Qty	P/N
1	Flushing canister	1	74350486
2	Universal flushing adapter set	1	3134
3	Red service hose 3/8" x 3/8" 3000 mm	1	3900171
4	Installation bracket	1	74350482
5	Installation screws 6 x 16 mm	2	417560616
6	Installation aluminum rings	2	74350488
7	Adapter 1/4" x 3/8" SAE	1	3900172
8	Adapter 1/4" SAE x HP R134a	1	3900173
9	Adapter 3/8" SAE x HP R134a	1	3900174
10	Stainless steel filter 50 µm	1	3900175

## 2.3 Principal specifications

Refrigerant:	<b>R134a</b>
Application:	<b>Personal cars, vans, cabin of trucks</b>
Maximum pressure (PS):	<b>21 bar</b>
Filtering performance:	<b>50 microns</b>
Canister capacity:	<b>6,2 Liters</b>
Service hose length:	<b>3000 mm</b>
Standards compliancy:	<b>CE - SAE J 2670</b>

## 3 INSTALLATION

### 3.1 Installation on Konfort units

This procedure explains how to install the flushing canister on the Konfort units.

**WARNING:** Prior opening the Konfort station, make sure that the units is switched-off and its power cable is disconnected from the main power source.



**a)** Remove the two screws fixing the control panel of the Konfort unit.



**f)** Present the flushing canister toward the two aluminium rings which you have just installed on the left side of the unit.

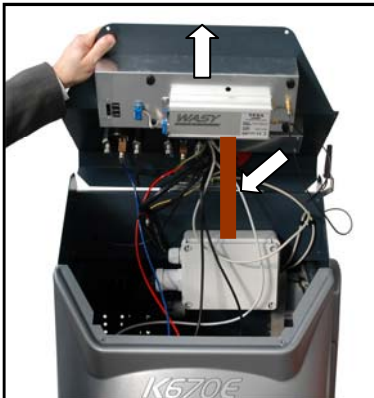

**b)** Lift up the control panel of the Konfort unit and secure it with the proper fixing bar.

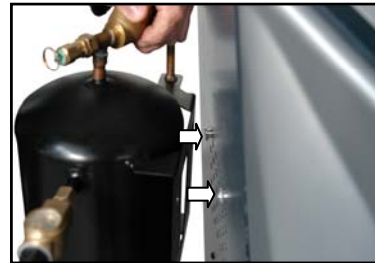

**g)** The two aluminium rings should be inserted in the two holes present on the base plate of the canister.



**h)** Once the two aluminium rings are inserted, the canister should slide down and finally sit on the surround of the rings.



**c)** Unpack the installation kit and verify if all components are present.

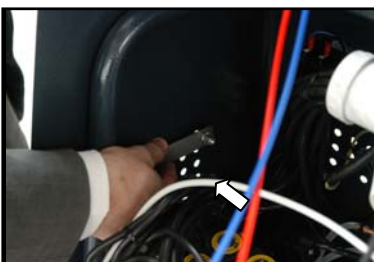

**d)** On the left lateral panel and from inside the unit, position the metallic installation bracket toward the upper line of ventilation holes.



**e)** Position the two screws with the two aluminium rings. Tight them with the required tool.



**i)** Now the main component of the flushing kit is installed on the Konfort unit ready for use.

It can still be easily removed in case of non-frequent use.

### 3.2 Flushing program activation

Turn-on the main power switch (position I (ON)).

When the unit is switched-on, the display shows the following information for a few seconds.

W	A	I	T	.	.	.	■												

At the end, the unit goes in stand-by mode.

R	e	f	r	i	g	e	r	a	n	t		g	.	X	X	X	X	X	
P	A	G		O	i	l						c	c	.	X	X	X	X	
U	V		A	d	d	i	t	i	v	e		c	c	.	X	X	X	X	
D	D	/	M	M	/	Y	Y					H	H	:	M	M	:	S	S

(Here is showed in example stand-by display of ECK650E and ECK670E)

With unit on Stand-by mode press **UP** or **DOWN**.

The Display shows:

D	A	T	A	B	A	S	E												
A	D	V	A	N	C	E	D		P	R	O	G	R	A	M				
O	T	H	E	R		M	E	N	U										◀
D	D	/	M	M	/	Y	Y					H	H	:	M	M	:	S	S

Press **UP** or **DOWN** to select **Other menu**. Press **Enter** to confirm.

The Display shows:

S	E	L	E	C	T		M	E	N	U									
V	E	S	S	E	L		F	I	L	L	I	N	G						
S	E	R	V	I	C	E	.												◀
D	D	/	M	M	/	Y	Y					H	H	:	M	M	:	S	S

Press **UP** or **DOWN** to select **Service**. Press **Enter** to confirm.

The Display shows:

E	N	T	E	R		P	A	S	S	W	O	R	D	.					

Type the code **3472** and press **Enter** to confirm.

The Display shows:

1	)		N	L		C	O	N	F	I	G	U	R	A	T	I	O	N	
2	)		P	A	S	C	A	L											
3	)		F	L	U	S	H	I	N	G		K	I	T					◀
4	)		M	U	L	T	I	-	P	A	S	S		R	E	C	.		

Press **UP** or **DOWN** to select **FLUSHING KIT** and press **Enter** to confirm.  
The Display shows:

I	n	s	t	a	l		f	l	u	s	h	i	n	g					
p	r	o	c	e	d	u	r	e	?										

Press **Enter** to confirm.  
The Display shows:

E	N	T	E	R		P	A	S	S	W	O	R	D	.					
						-	-	-	-										

Press **Stop** to go back in stand-by mode.  
Flushing program is **activated**.

### 3.3 Setup of flushing timing

Depending on the capacity of the system to flush you may have to modify the flushing timing parameter. A large capacity system (vans, trucks) will require more refrigerant to perform the flushing process. In this menu you can change the quantity of refrigerant used for flushing the system.

The unit is in stand-by mode.  
The Display shows:

R	e	f	r	i	g	e	r	a	n	t		g	.	X	X	X	X	X	
P	A	G		O	i	l						c	c	.	X	X	X	X	
U	V		A	d	d	i	t	i	v	e		c	c	.	X	X	X	X	
D	D	/	M	M	/	Y	Y					H	H	:	M	M	:	S	S

(Here is showed in example stand-by display of ECK650E and ECK670E)

With unit on Stand-by mode press **UP** or **DOWN**.



The Display shows:

D	A	T	A	B	A	S	E												
A	D	V	A	N	C	E	D		P	R	O	G	R	A	M				
O	T	H	E	R		M	E	N	U								◀		
D	D	/	M	M	/	Y	Y					H	H	:	M	M	:	S	S

Press **UP** or **DOWN** to select **Other menu**. Press **Enter** to confirm.  
The Display shows:

S	E	L	E	C	T		M	E	N	U									
V	E	S	S	E	L		F	I	L	L	I	N	G						
S	E	R	V	I	C	E	.										◀		
D	D	/	M	M	/	Y	Y					H	H	:	M	M	:	S	S

Press **UP** or **DOWN** to select **Service**. Press **Enter** to confirm.  
The Display shows:

E	N	T	E	R		P	A	S	S	W	O	R	D	.				
						-	-	-	-									

Type the code **3587** and press **Enter** to confirm.  
The Display shows:

F	L	U	S	H	I	N	G		D	E	F	A	U	L	T		
T	I	M	E														
s	e	c	.														
				X	X	X											

Press **Enter** to modify the XXX value for flushing time.

Type the required flushing timing using the numeric keyboard (max range is 1 – 90 seconds)  
**36 sec** is the default value suitable to most of personal cars having a maximum capacity of about **1500 gr** refrigerant.

For setting-up **larger systems** you need to consider about **30 sec per 1000 gr** of flushing refrigerant. (In example for a system with about 2000 gr refrigerant, you need to set a flushing timing of 48 sec.)

When the timing is set Press **Enter** to confirm, and then **Stop** twice to quit setup menu.

### 3.4 Flushing program deactivation

Turn-on the main power switch (position I (ON)).

When the unit is switched-on, the Display shows the following information for a few seconds.

W	A	I	T	.	.	.	■												

At the end, the unit goes in stand-by mode.

R	e	f	r	i	g	e	r	a	n	t	g	.	X	X	X	X	X		
P	A	G		O	i	l					c	c	.	X	X	X	X		
U	V		A	d	d	i	t	i	v	e		c	c	.	X	X	X	X	
D	D	/	M	M	/	Y	Y				H	H	:	M	M	:	S	S	

(Here is showed in example stand-by display of ECK650E and ECK670E)

With unit in Stand-by mode press **UP** or **DOWN**.

The Display shows:

D	A	T	A	B	A	S	E												
A	D	V	A	N	C	E	D		P	R	O	G	R	A	M				
O	T	H	E	R		M	E	N	U										◀
D	D	/	M	M	/	Y	Y				H	H	:	M	M	:	S	S	

Press **UP** or **DOWN** to select **Other menu**. Press **Enter** to confirm.

The Display shows:

S	E	L	E	C	T		M	E	N	U									
V	E	S	S	E	L		F	I	L	L	I	N	G						
S	E	R	V	I	C	E	.												◀
D	D	/	M	M	/	Y	Y				H	H	:	M	M	:	S	S	

Press **UP** or **DOWN** to select **Service**. Press **Enter** to confirm.

The Display shows:

E	N	T	E	R		P	A	S	S	W	O	R	D	.					

Type the code **3472** and press **Enter** to confirm.

The Display shows:

1)	N	L	C	O	N	F	I	G	U	R	A	T	I	O	N
2)	P	A	S	C	A	L									
3)	F	L	U	S	H	I	N	G	K	I	T				◀
4)	M	U	L	T	I	-	P	A	S	S	R	E	C	.	

Press **UP** or **DOWN** to select **3) FLUSHING KIT** and press **Enter** to confirm.

The Display shows:

U	n	i	n	s	t	a	l		f	l	u	s	h	i	n	g
p	r	o	c	e	d	u	r	e	?							

Press **Enter** to confirm.

The Display shows:

E	N	T	E	R		P	A	S	S	W	O	R	D	.		
						-	-	-	-							

Press **Stop** to go back in stand-by mode.

Flushing program is **deactivated**.

## 4 SAFETY

The advanced technology adopted in the design and production of Konfort unit and its flushing kit makes this equipment extremely simple and reliable in the performance of all procedures. Therefore, the user is not exposed to any risk if the general safety rules reported below are followed with proper use and maintenance of the unit.

### 4.1 General Safety Rules

- ❑ This equipment is intended for use by **QUALIFIED PERSONNEL** only. Such users must have a knowledge of the basics of refrigeration, refrigeration system, refrigerants and the potential hazards that unit under high pressure can cause.
- ❑ **Never** change or modify the safety valve.
- ❑ **Never** smoke or use the equipment near open flames and hot surfaces. At high temperatures, the refrigerant decomposes, releasing toxic and chemical substances that are hazardous for users and the environment.
- ❑ **Never** release refrigerant to atmosphere. All refrigerant should be recovered into suitable containers (refillable containers).
- ❑ **Always** read this manual carefully before use.
- ❑ **Always** supervise the system at all times.
- ❑ **Always** use only **R134a**. Mixtures with other types of refrigerant could seriously damage the cooling and refrigeration system, as well as the service equipment.
- ❑ **Always** wear safety glasses and protective clothing as gloves when handling any refrigerants. Exposure to their very low boiling point ( $-26,3\text{ }^{\circ}\text{C}$ ), even for very short periods of time can cause extreme personal injury. (burns)
- ❑ **Avoid** inhaling refrigerant or vaporized lubricants (compressor – dye); this could lead to irritation of eyes, nose and throat.
- ❑ **Warning:** Ensure that all valves are closed before making connections between the service station, A/C system and the flushing equipment.
- ❑ **Warning:** Ensure that all phases have been completed and that all valves are closed before disconnecting the service station. This will prevent release of the refrigerant into the atmosphere.
- ❑ **Warning:** All of the flexible hoses may contain refrigerant under high pressure.
- ❑ **Warning:** Ensure that the service couplers have been closed (anticlockwise) before connecting to system to flush.
- ❑ **Warning:** Always perform leak testing procedure before proceeding with flushing. following operating instructions, to avoid any risk of refrigerant leakage.
- ❑ **Warning:** The flushing kit and A/C system in vehicles containing R134a should not be tested with compressed air. Some mixtures of air and 134a have proven to be combustible at high pressure levels. These mixtures are potentially hazardous and there is a risk of fire and explosions that can cause damage to property and personal injury. Additional medical and safety information can be obtained from the manufacturers of the oils and refrigerants.



## 4.2 Guidelines for Handling Refrigerants

### 4.2.1 Glossary of Terms

- ❑ **Refrigerant:** Refrigerant fluid (Exclusively. **R134a** ).
- ❑ **A/C System:** Air-conditioning system in the vehicle.
- ❑ **Flushing:** Action of rinsing the A/C system and/or components.
- ❑ **Unit / service station:** Texa Konfort K605E, K610E, K610E BUS, K650E, K670E.
- ❑ **Internal vessel:** Refrigerant storage tank.
- ❑ **Phase:** Execution of an individual function (Ex. Vacuum).
- ❑ **Cycle:** Execution of more phases.
- ❑ **Recovery:** The recovery of refrigerant in any condition and its storage in a container outside the A/C system, without necessarily undergoing analysis or treatment of any kind.
- ❑ **Recycling:** A reduction of the contaminating substances in used refrigerants through oil separation, the recovery of incondensable and their single or multiple passages through elements that enable a reduction in humidity, acidity and particles.
- ❑ **TXV:** Thermostatic Expansion Valve
- ❑ **Vacuum:** Phase in which incondensable and moisture are evacuated from an A/C system solely by means of a vacuum pump.

### 4.2.2 Precautions for refrigerant storage

The refrigerant to be removed from a system must be handled carefully in order to prevent or minimise the possibilities of different refrigerants mixing.

The Konfort A/C service stations are specifically designed for the treatment of the **R134a**.

The tank used for storing refrigerants must be assigned to specific refrigerants to avoid different refrigerants mixing.

The tank used must be free of oil and other contaminants and must be clearly marked in order to identify the refrigerants they contain.

### 4.2.3 Conditions of the refrigerant and the system

A system's history and age can be important factors in deciding whether a system's refrigerant is to be recycled.

Installation and maintenance procedures carried out during the system's service life have a considerable effect on the quality of the refrigerant.

Systems that have not been cleaned or properly evacuated may have high levels of contamination in the refrigerant and in the oil. If the system's history is unknown, the refrigerant removed must be at least recycled before being re-introduced into the system.

When users are unsure of the level of the refrigerant's contamination, preliminary checks can be performed using special kits for measuring acidity and humidity.

### 4.2.4 Recycling Capacity

The unit's recycling filter system should be replaced regularly in order to maintain the efficiency of the recycling unit.

#### 4.2.5 General Notions

Before re-introducing refrigerant into the system, the system itself must be evacuated and cleaned.

In order to be sure that the system is free of contamination before introducing the refrigerant, all the procedures described in this instruction manual must be followed.

Clean and maintain the units regularly, especially when highly contaminated refrigerant is used: it is extremely important that contamination from the previous operation is not transferred to subsequent operations.

### 4.3 Safety Devices

ACKF01 flushing kit is equipped with an overpressure valve. This valve opens when the PS value is reached.

~~Any type of tampering with the safety device mentioned above is hereby prohibited.~~

**NEVER approach the overpressure valve when opened. Danger of pressurized refrigerant discharge.**

### 4.4 The Work Environment

- ❑ The flushing process must be performed in open environments or in places equipped with good ventilation (at least 4 changes of air per hour).
- ❑ The Konfort A/C service stations are designed for being used at a maximum altitude of 1000 m above sea level, within a temperature range of +5 and +50°C and with a maximum humidity of 50% at +40°C.
- ❑ Operate in sufficiently lit conditions (The medium value of working illumination for mechanical and assembly workshops (with fine workbenches) is 500-750-1000 lux).

## 5 INTRODUCTION TO FLUSHING WITH REFRIGERANT

### 5.1 What is Flushing?

Flushing with refrigerant is an action performed in order to remove solid contamination and old compressor lubricant out from the A/C system. Using liquid refrigerant avoid the risk of damaging internal components with aggressive detergents. In practice, once all refrigerant is removed from the A/C system, most of the solid contamination is sticking to the lubricant staying in the A/C circuits and component. Using refrigerant you will flush all the oil and the loose solid contamination.

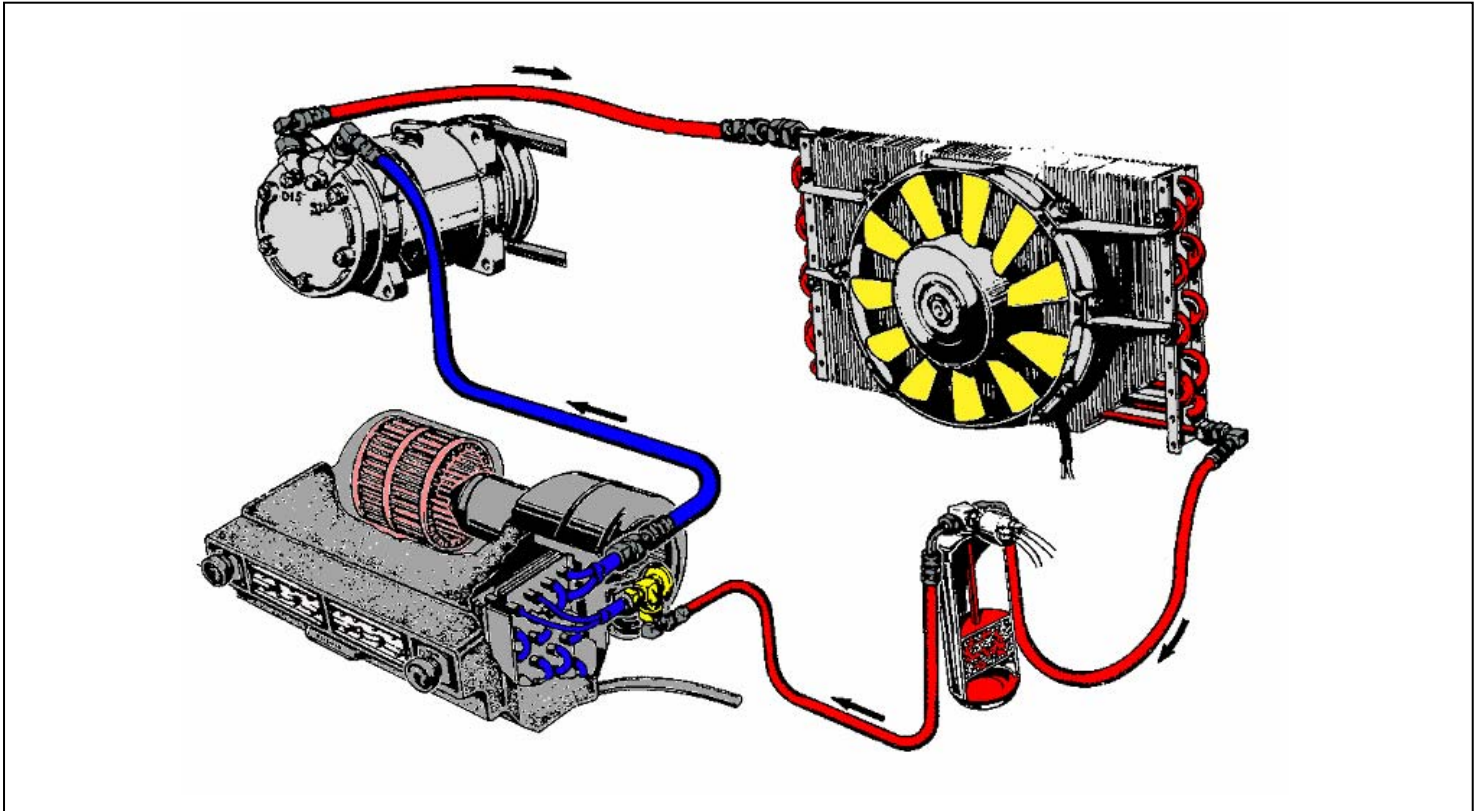

### 5.2 Why Flushing is important?

With respect to A/C system operation, component life expectancy and cooling performance, it's of utmost importance to maintain a clean A/C system. Even the smallest particle of contamination can cause restrictions and problems that will compromise the system. According to A/C component manufacturers and rebuilders, flushing is important for warranty purposes. In most cases if you do not flush the system, you will void warranty on the components.

After a first component failure (i.e. compressor), you can assume that the system is most likely contaminated. The replacement parts (rebuilt or new) will surely fail for the very same reason, if the system is not cleaned out properly. Regardless of the failure that the A/C system has experienced, when the system is flushed properly, it will be as clean (internally) as it was from the factory and the full performance will be restored. Also the proper flow of refrigerant and (more importantly) oil, will be restored, assuring long life from all the system.

### 5.3 When do you flush the A/C system?

There are many reasons which would justify to flush the A/C system. However the summary of the key priorities is the following:

- When dirt or other contamination are present in the A/C circuits.
- When a system leakage, may have generated the presence of humidity.
- When the refrigerant circuits have been left open for a long time. (i.e. after an accident)
- When the system contains moisture, due to incorrect servicing or saturated filter drier.
- When there is a doubt about the amount of lubricant and UV additive present in the system.
- When the compressor has to be replaced due to internal damages.
- When the vehicle manufacturer prescribes to do it.

### 5.4 Examples of system contamination

Typically, A/C system contamination is in the form of dark oil, foreign materials or debris including metal filings, aluminium corrosion (usually in the form of a white powder) or pieces of compressor piston ring material or o-rings. Any particles found in the system or on the **orifice tube inlet screen is considered contamination and the system should be flushed.**

**Dark lubricant:** Is usually a sign of compressor piston ring failure. Premature wear on compressor piston rings which are typically black Teflon, causes the system oil turn black.

**Metal particles:** Is a sign of compressor wear.

**Black particles:** Is a indicating that piston rings start to wear excessively, leaving small black particles on the inlet of the orifice tube.

**White powder:** Is a sign of aluminium corrosion. The A/C system is suffering from extreme moisture contamination. Moisture mixed with refrigerant, forms harmful acids which will corrode aluminium components. In this situation look for leaks at heat exchangers (condenser and evaporator) as they are the thinnest metal components and usually the first to leak.

**Rubber particles:** Is a sign of serious contamination and improper servicing of the A/C system. O-Rings can easily deteriorate and fall apart when non approved additives, solvents or chemical sealers are used in system.





## 5.5 Components sensible to contamination



### Fixed orifice tubes:

If you are working on an orifice tube system always remove and inspect it. The inlet screen will provide the best indication of contamination in the A/C system. Never try to clean the orifice tube. It **should always be replaced** when there is any sign of debris or contamination.

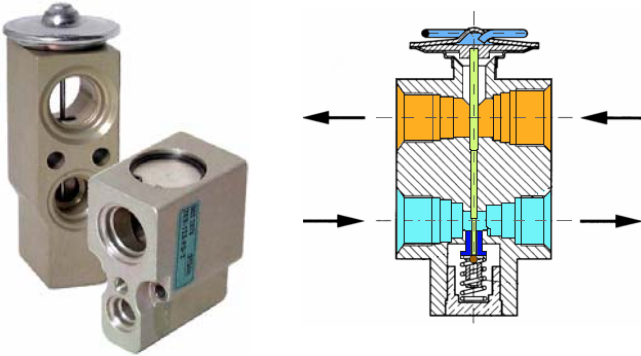

### Block type expansion valves:

Block type expansion valves should never be flushed. If a restriction is suspected, it will have to be replaced. These valves do not typically include a protective inlet filter. If a valve restriction is suspected, **it will need replacement.**

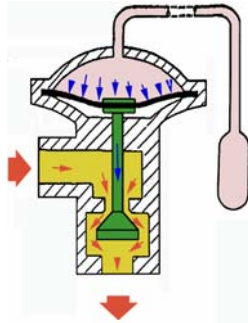

### Thermostatic expansion valves (TXV):

Thermostatic expansion valves could include an inlet filter. Typically, they are conic and press fit into the valves inlet. They can be removed and cleaned. However the valve itself can not be flushed. If a valve restriction is suspected, **it will need replacement.**



Condenser



Evaporator

### Condensers and evaporators:

These components are also sensible to restrictions caused by contamination. Especially the **Multipass Types** having very small and multiple orifices in which the refrigerant is flowing.

If some of these orifices are plugged, it is nearly impossible to clean them and the **replacement of the entire component is the only solution.**

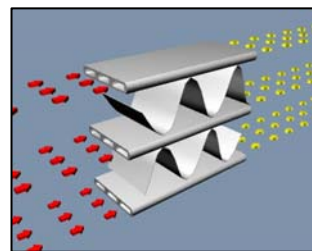

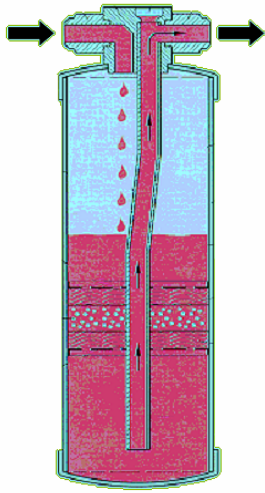

Receiver drier

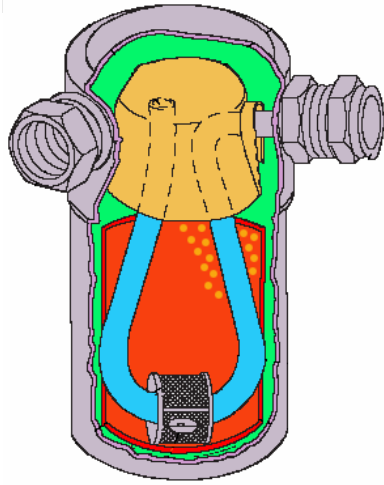

Accumulator

### Receiver driers & accumulators:

Both driers and accumulators include fine screens and desiccant. The flow of refrigerant through these components is not a straight path, so they can not be flushed. These components **always require replacement**.



### Compressors:

Compressors are definitively sensible to the quality and the cleanness of the lubricant. In fact the A/C system contains oil which is transported by the refrigerant in order to lubricate the compressor. (like a two strokes engine). Contaminated oil is not giving the required lubrication, as dirt particles are acting as abrasive paper, damaging the moving components.

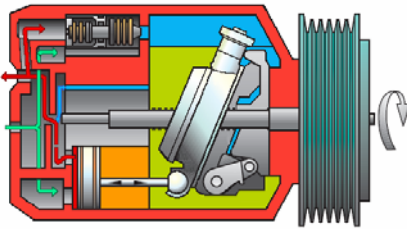

Contamination with solid particles will always drive the **compressor to failure**.



### Hoses and tubing:

Restrictions and junction points of connecting hoses and tubing are also strategic areas which can retain contaminations and be subject **to blockage**.

## 6 FLUSHING METHOD WITH ACKF01 KIT

### 6.1 Preliminary measures

- Position the vehicle in the service area.
- Turn off the engine.
- Open the hood and disconnect the battery.
- Respect safety rules for handling refrigerant.
- Make sure the A/C system is empty from any refrigerant.
- Remove the compressor.
- Remove the receiver drier or the accumulator.
- Remove the expansion valve or the orifice tube.

### Components to remove from A/C systems with block type expansion valve

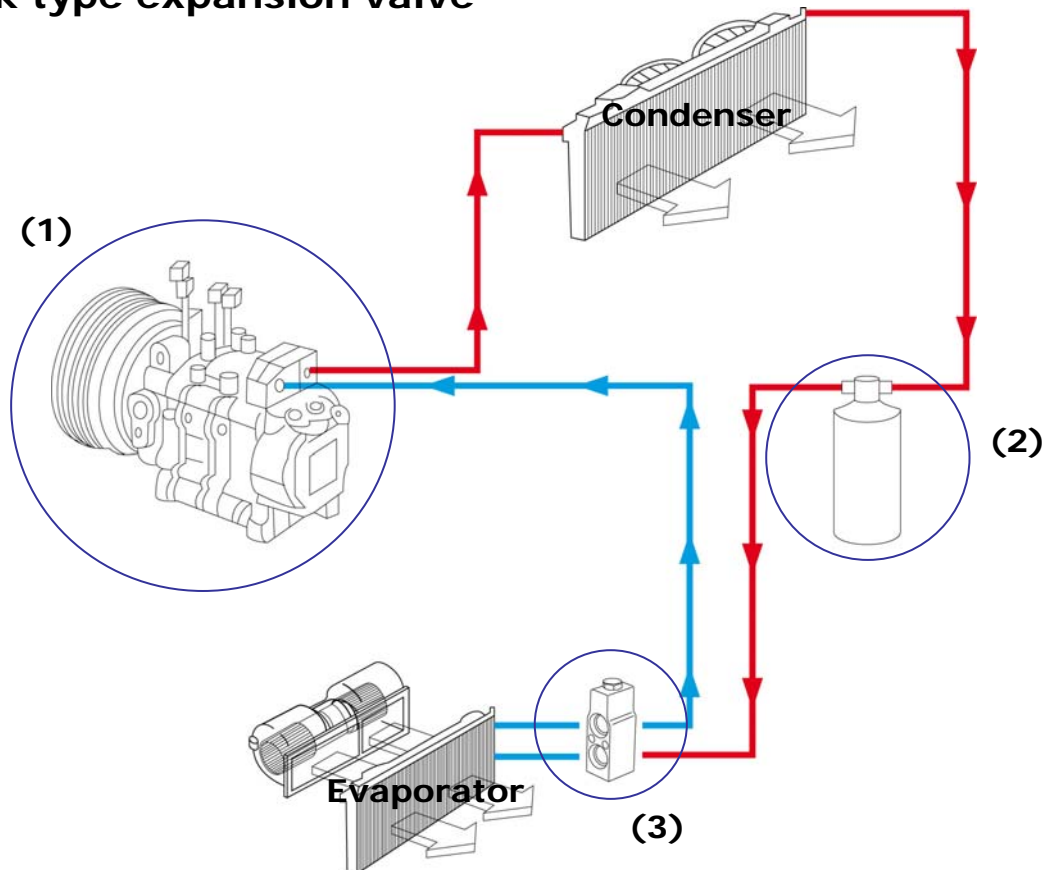

- (1) Compressor
- (2) Receiver drier
- (3) Block type expansion valve

## Components to remove from A/C systems with TXV

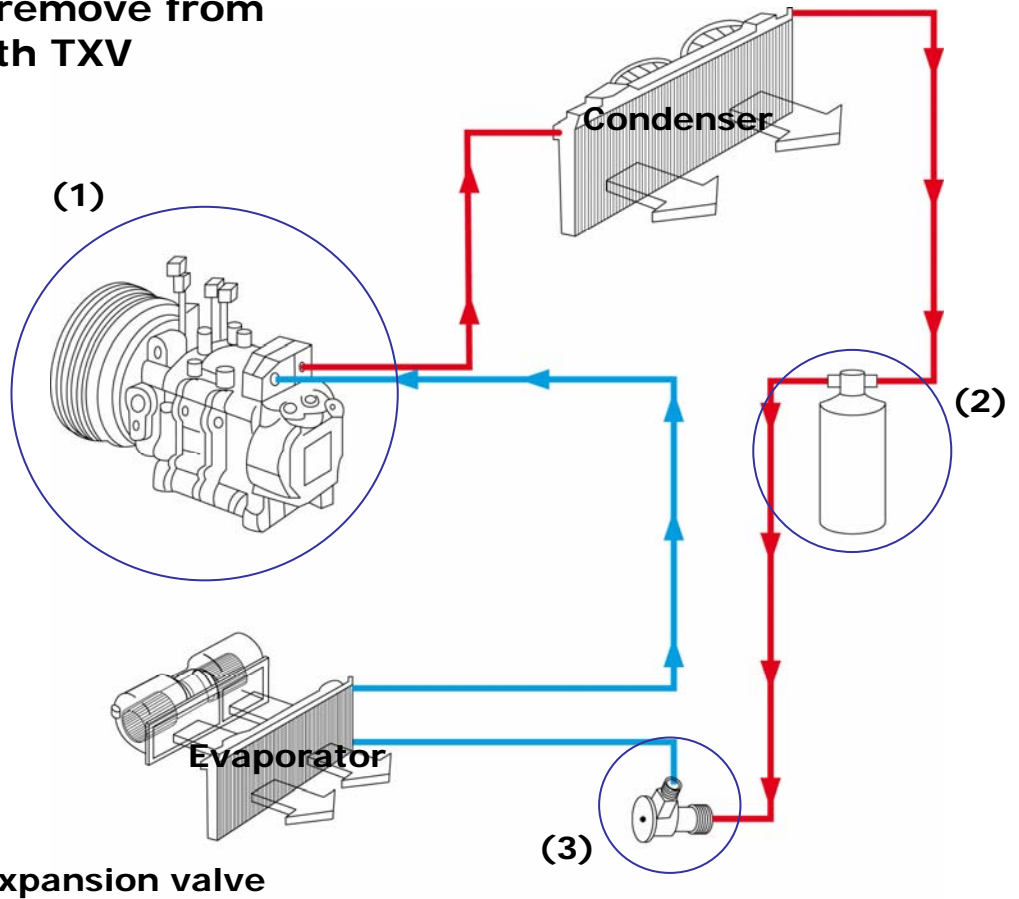

## Components to remove from A/C systems with orifice tube

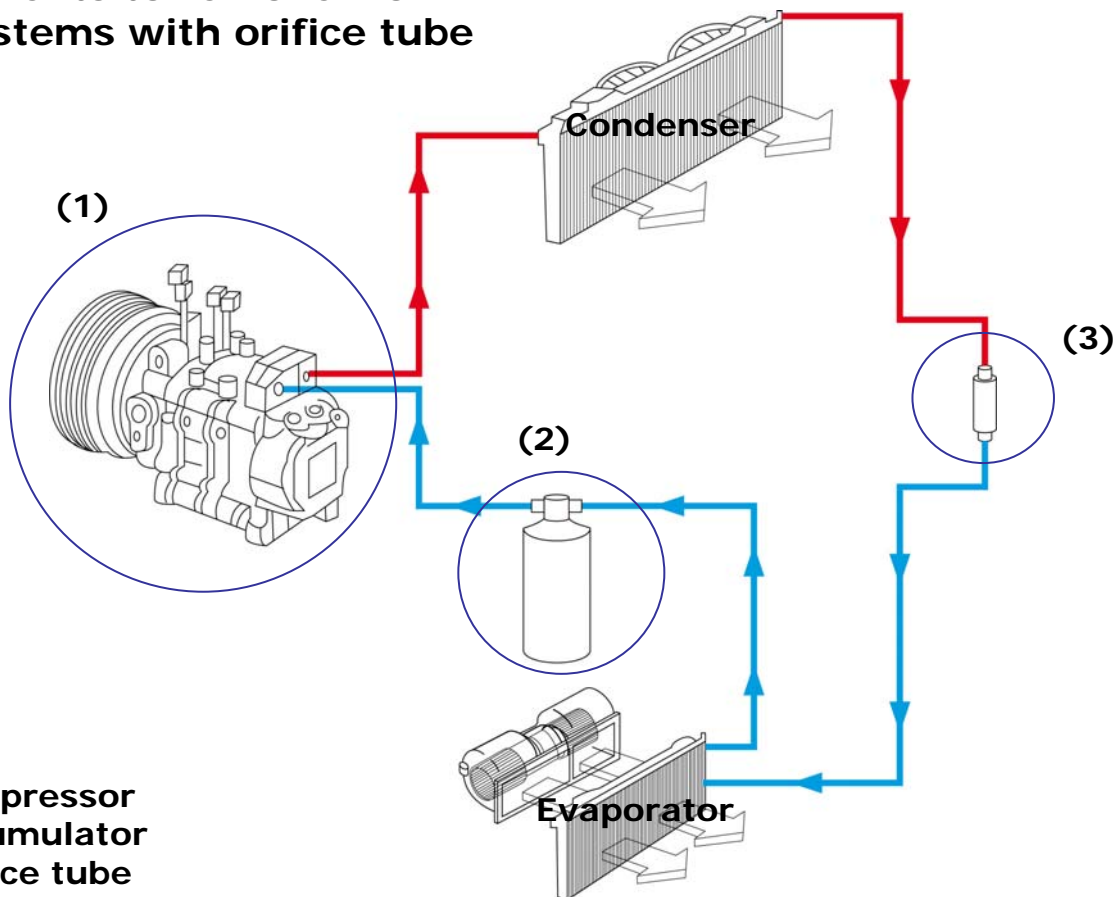

## 6.2 Konfort unit preparation for flushing

The following steps are required to set the unit for flushing.

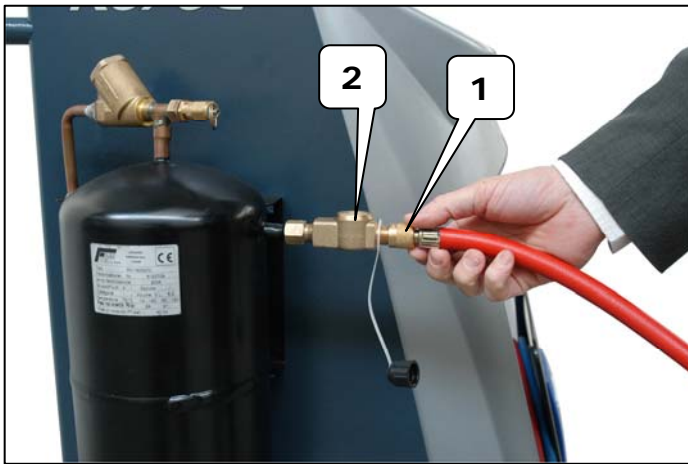

Connect :

- (1) Red flushing hose P/N 3900171
- (2) Inlet of flushing canister P/N 74350486

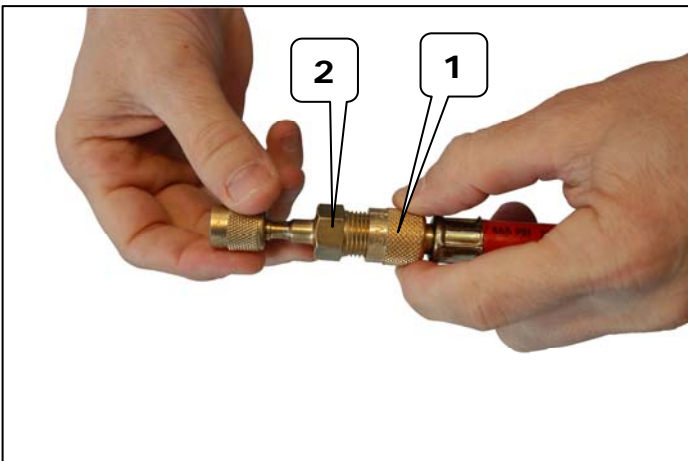

Connect :

- (1) Red flushing hose P/N 3900171
- (2) 1/4" x 3/8" adapter P/N 3900172

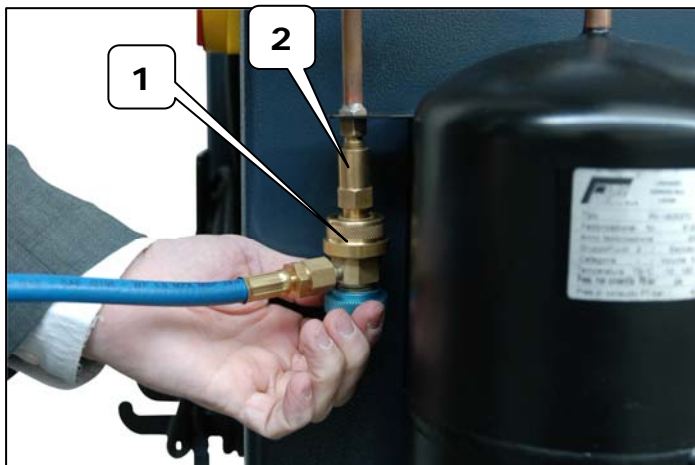

Connect :

- (1) Konfort unit's blue service hose
- (2) Outlet of flushing canister P/N 74350486



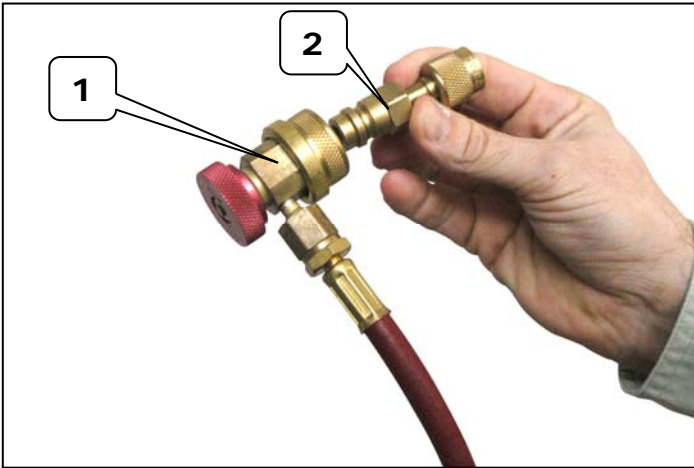

Connect :

- (1) Konfort's red service hose
- (2) ¼" x HP R134A adapter P/N 3900173

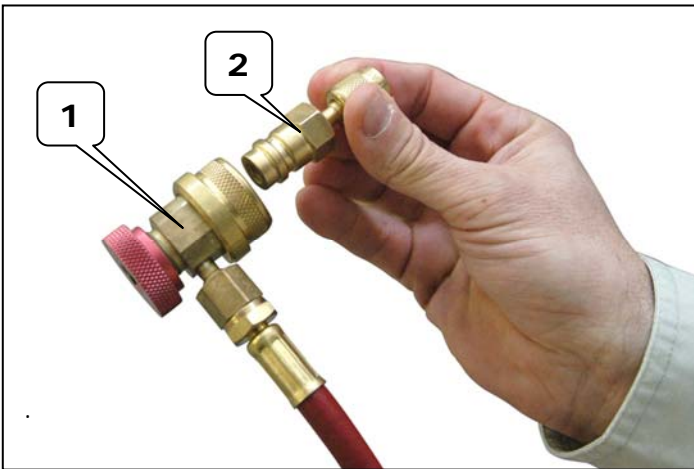

If using the Audi-Volkswagen adapter set connect :

- (1) Konfort unit's red service hose
- (2) 3/8" x HP R134A adapter P/N 3900174.

(Audi-Volkswagen adapter set is not included with the flushing kit. It needs to be purchased from VW Group directly)



Before flushing, make sure that Konfort unit's oil drain bottle is empty. (in order to avoid any overflowing of oil or UV additive)



Before flushing, make sure that the Konfort unit does contain **at least 5 kg** of R134a refrigerant.

If the A/C station requires refilling, please refer to Konfort operating manuals for instructions.

### 6.3 Installation of bridges and adapters

Depending on the system configuration, you need to install adapters and bridges supplied with the kit. The next 3 drawings are illustrating common situations encountered on A/C systems.

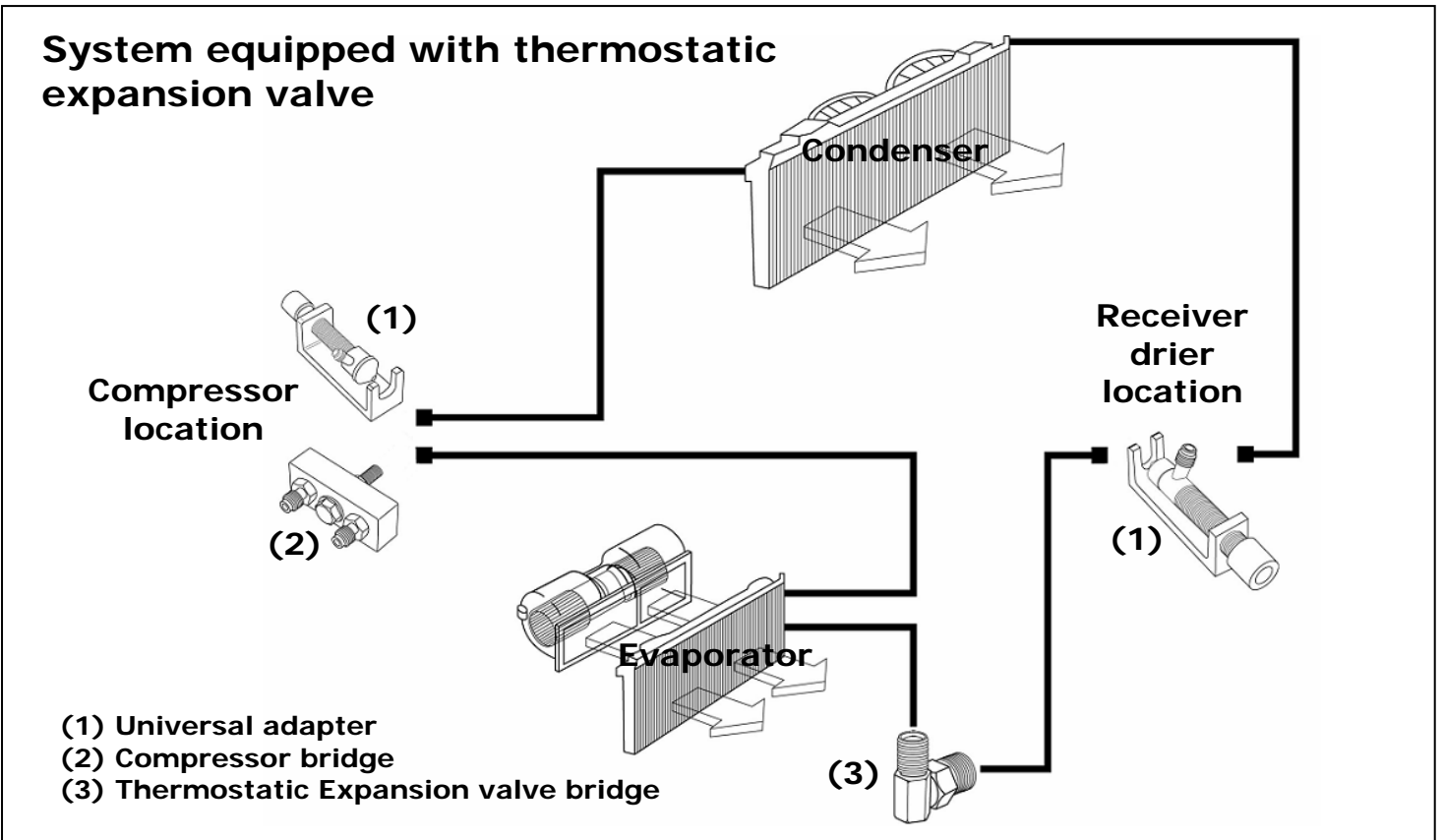
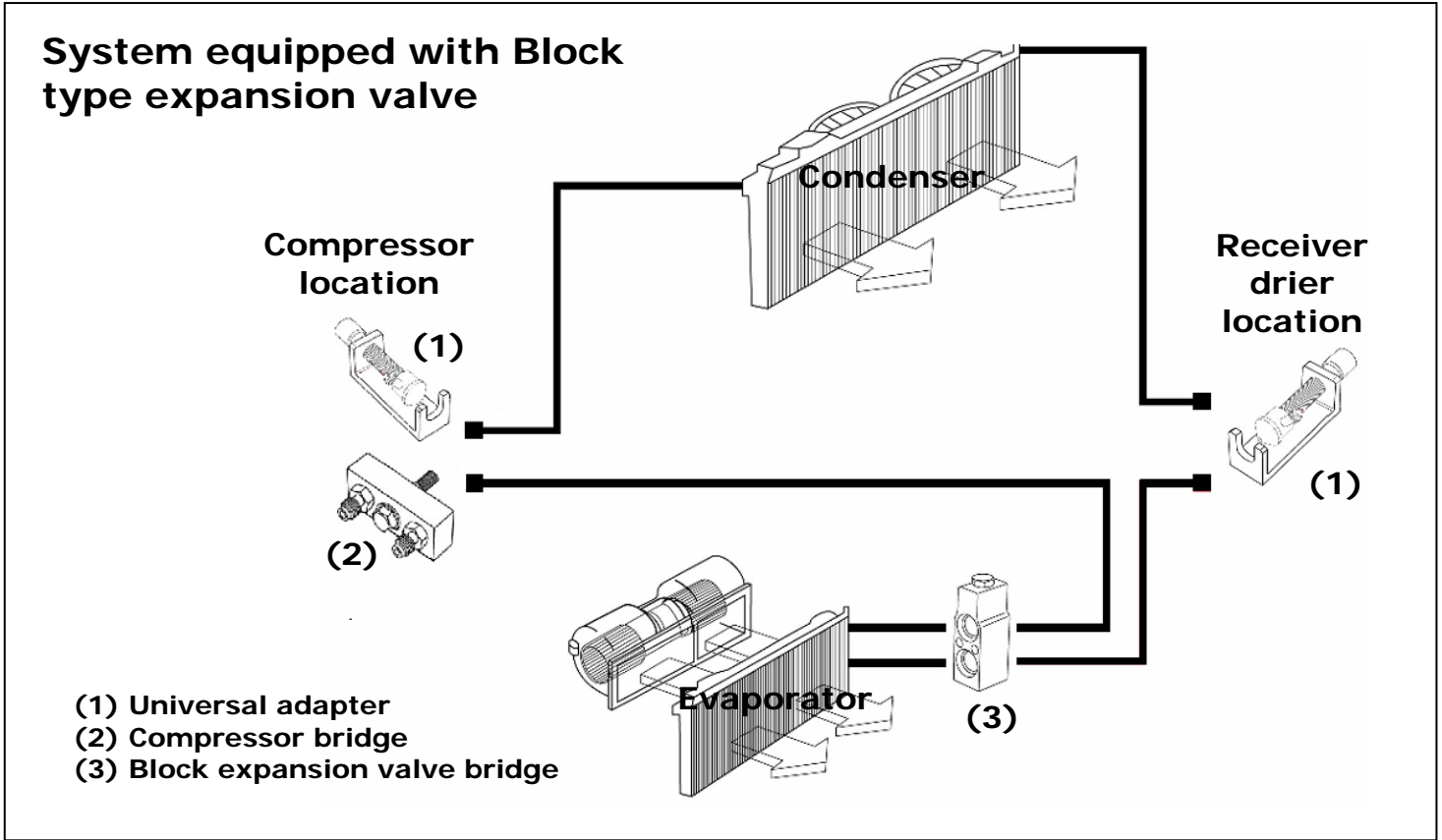

**System equipped with  
orifice tube**

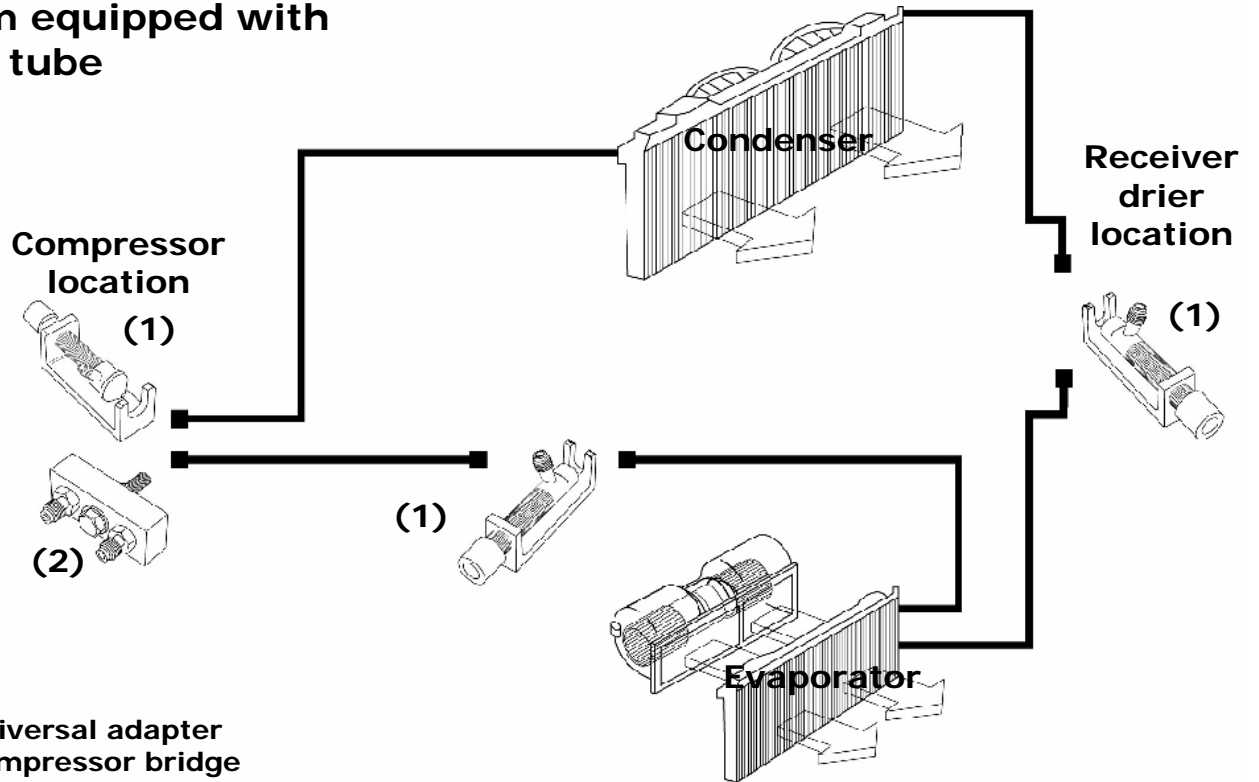

**Universal flushing adapter set P/N 3134**



## 6.4 Examples of adaptors and connections for flushing

Following are described various examples of connections which can be used for flushing the A/C systems. You need to choose the appropriate connection depending on configuration of the encountered system. (The Universal flushing adapter case P/N 3134, contains about 60 different types of adapters)

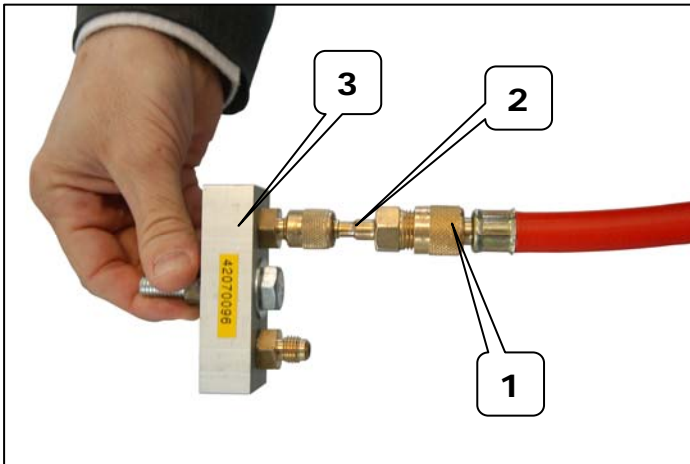

### Example 1

- (1) Red flushing hose P/N 3900171
- (2) 1/4" x 3/8" adapter P/N 3900172
- (3) Compressor bridge P/N 42070096

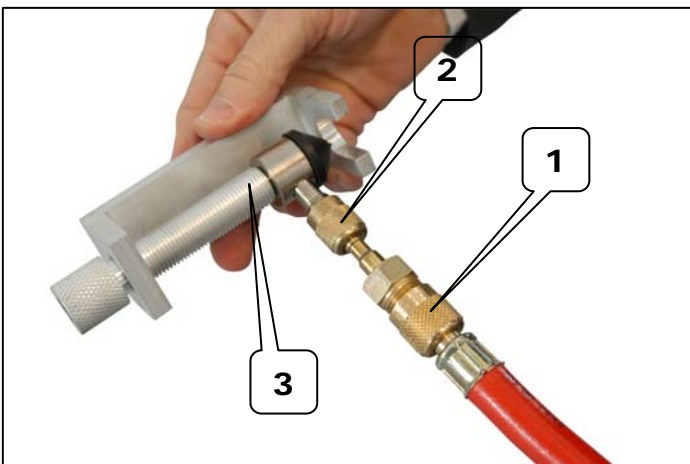

### Example 2

- (1) Red flushing hose P/N 3900171
- (2) 1/4" x 3/8" adapter P/N 3900172
- (3) Universal adaptor P/N 42070098

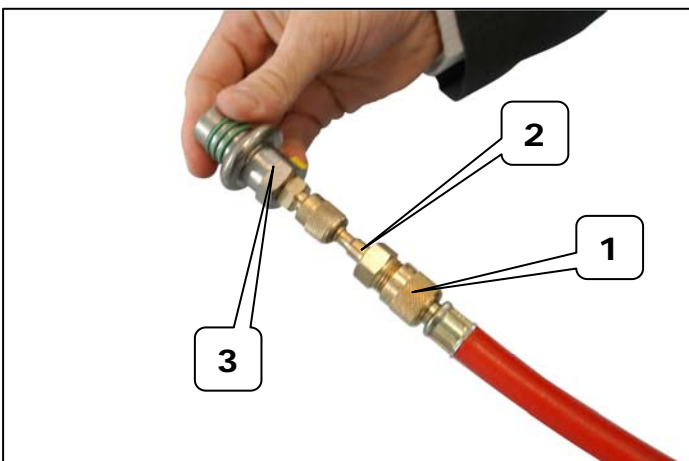

### Example 3

- (1) Red flushing hose P/N 3900171
- (2) 1/4" x 3/8" adapter P/N 3900172
- (3) "Spring-lock" adaptor P/N 42070086

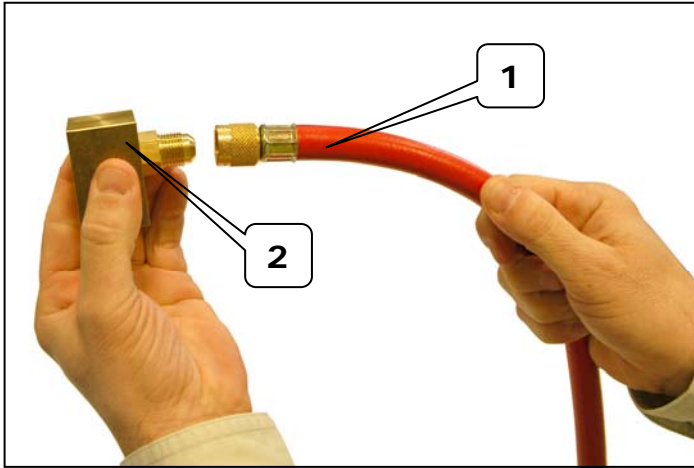

**Example 4**

If using the VW-AUDI specific flushing adapter set :

- (1) Red flushing hose P/N 3900171
- (2) Audi-Volkswagen specific adaptor

(Audi-Volkswagen adapter set is not included with the flushing kit. It needs to be purchased from VW Group directly)

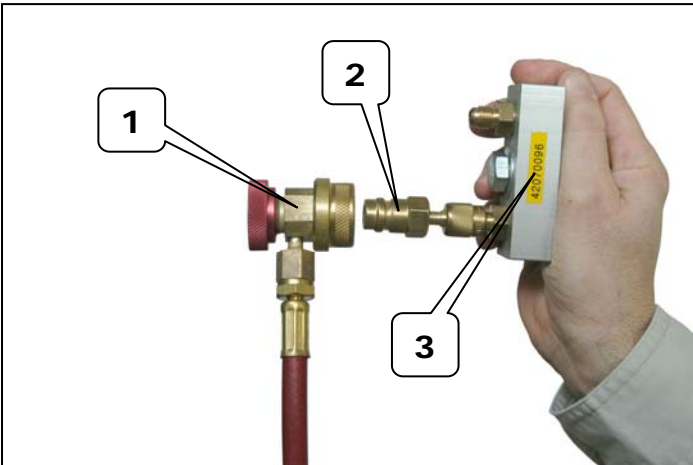

**Example 5**

- (1) Konfort unit's red service hose
- (2) ¼" x R134A adapter P/N 3900173
- (3) Compressor bridge P/N 42070096

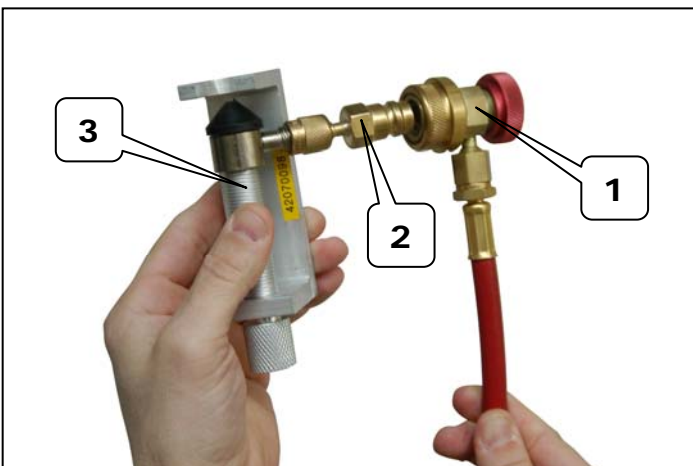

**Example 6**

- (1) Konfort unit's red service hose
- (2) ¼" x R134A adapter P/N 3900173
- (3) Universal adaptor P/N 42070098

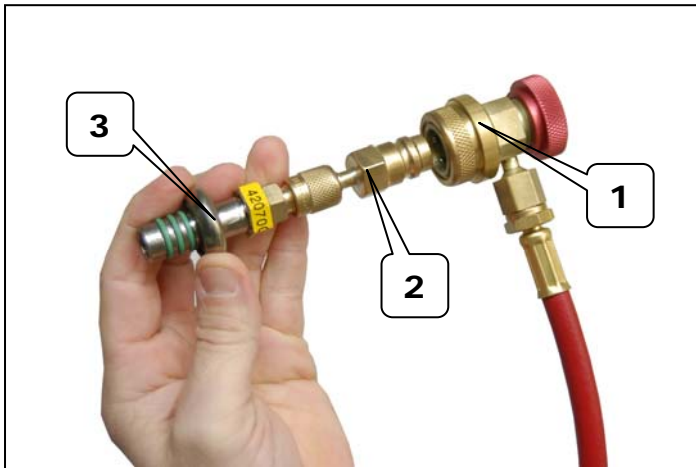

### Example 7

- (1) Konfort unit's red service hose
- (2) 1/4" x R134a adapter P/N 3900173
- (3) "Spring-lock adaptor P/N 42070086

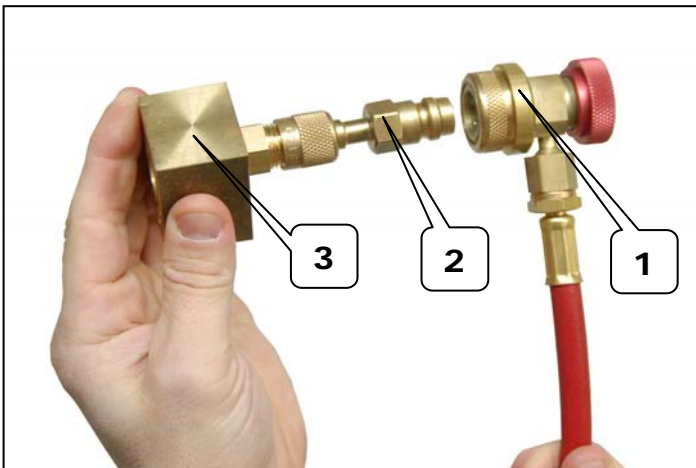

### Example 8

If using the VW-AUDI specific flushing adapter set :

- (1) Konfort's red service hose
- (2) 3/8" x HP R134A adapter P/N 3900174
- (3) Audi-Volkswagen specific adaptor.

(Audi-Volkswagen adapter set is not included with the flushing kit. It needs to be purchased from VW Group directly)

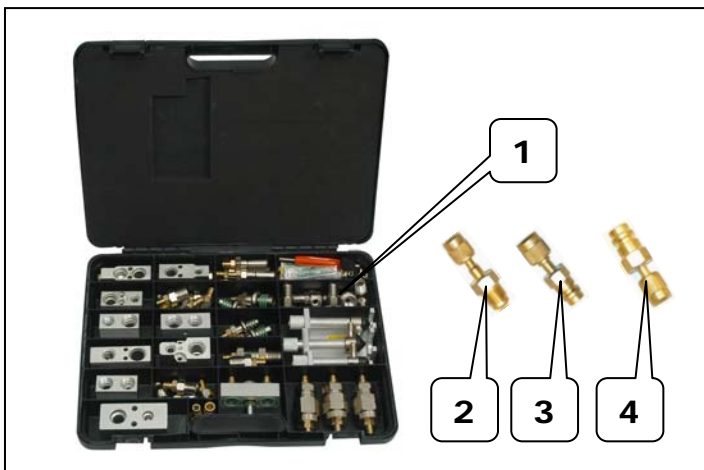

### Example 9

Illustration of the full set of flushing adapters included in the kit:

- (1) Universal flushing adapter set P/N 3134
- (2) Adaptor 1/4" x 3/8" P/N 3900172
- (3) Adaptor 1/4" x HP R134a P/N 3900173
- (4) Adaptor 3/8" x HP R134a P/N 3900174

## 6.5 Flushing systems with expansion valve

### 6.5.1 Flushing the evaporator side

In order to prevent particles from the faulty compressor contaminating the rest of the system; start flushing towards the compressor location in the regular flow of the A/C system .

Connect the Konfort unit to system as following :

- (1) Konfort red service hose with HP coupler to the receiver drier location
- (2) Canister red service hose 3/8" SAE P/N 3900171 to the compressor location

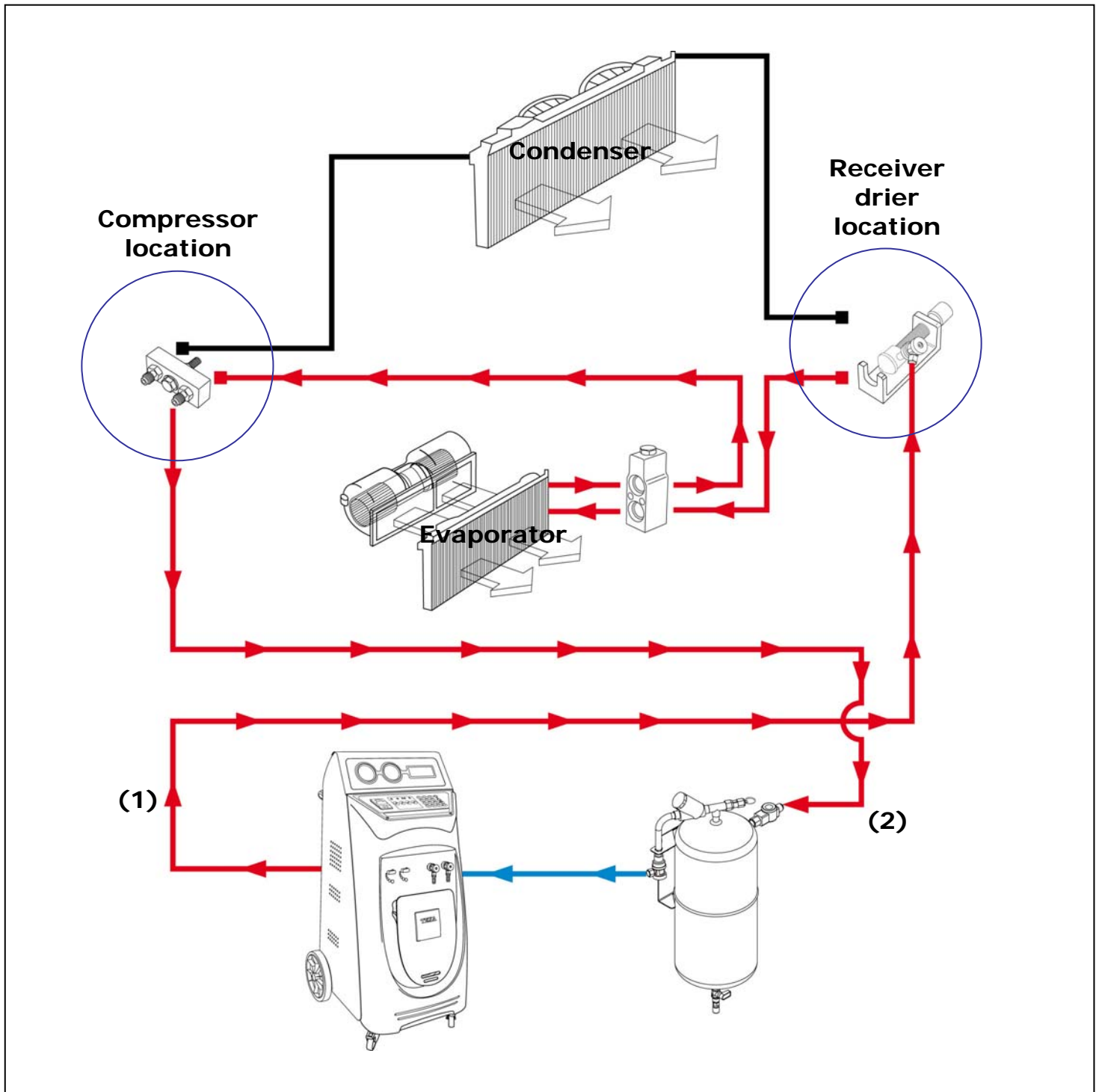

### 6.5.2 Back-flushing the evaporator side

In order to perform the final pass of flushing, reverse the connections to the system. In this situation you will be back-flushing towards the receiver drier location and against the regular flow of the A/C system.

Connect the Konfort unit to system as following :

- (1) Konfort red service hose with HP coupler to the compressor location**
- (2) Canister red service hose 3/8" SAE P/N 3900171 to the receiver drier location**

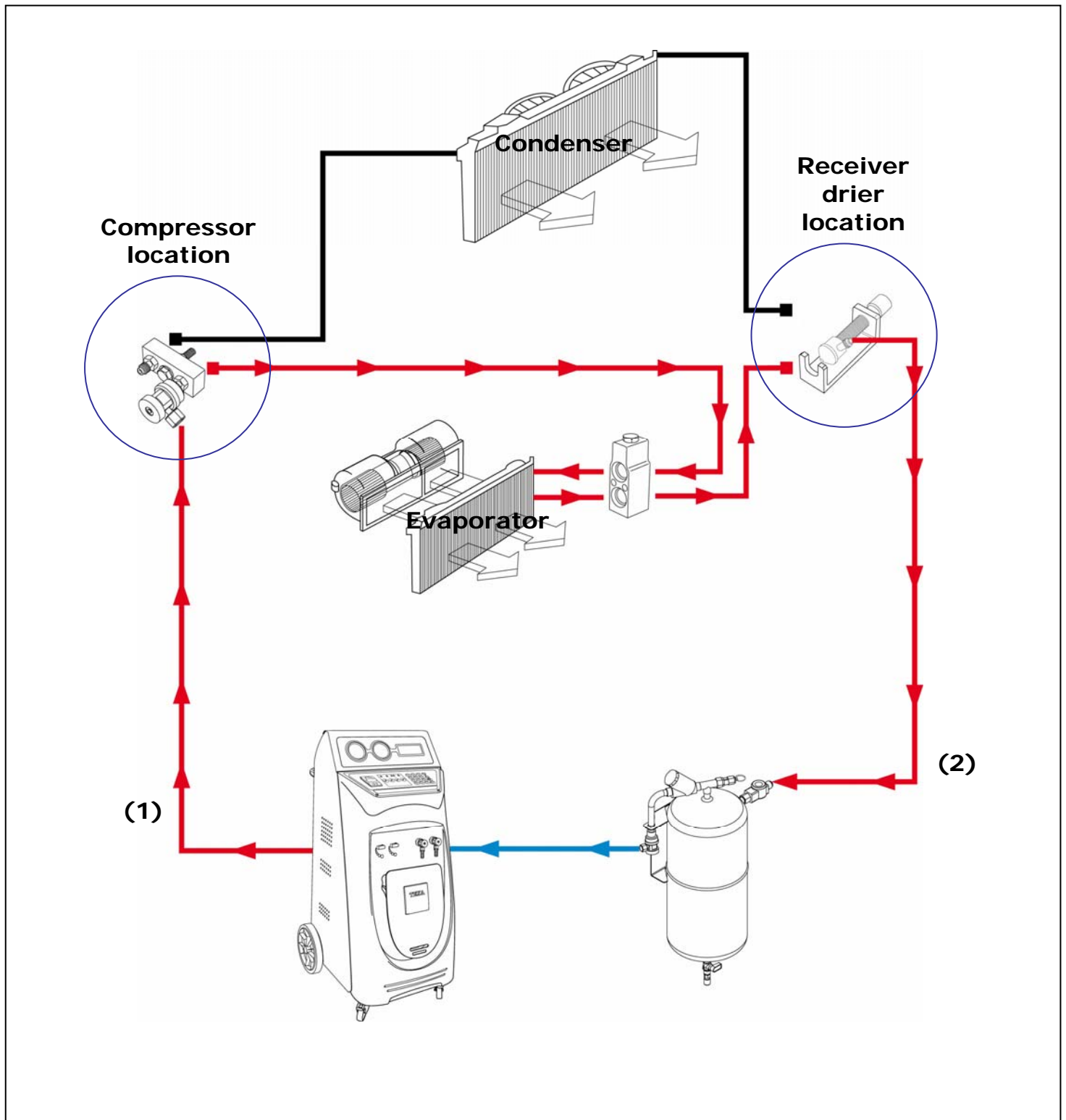

### 6.5.3 Flushing the condenser side

In order to prevent particles from the faulty compressor contaminating the rest of the system; start flushing towards the compressor location against the regular flow of the A/C system .

Connect the Konfort unit to system as following :

- (1) Konfort red service hose with HP coupler to the receiver drier location**
- (2) Canister red service hose 3/8" SAE P/N 3900171 to the compressor location**

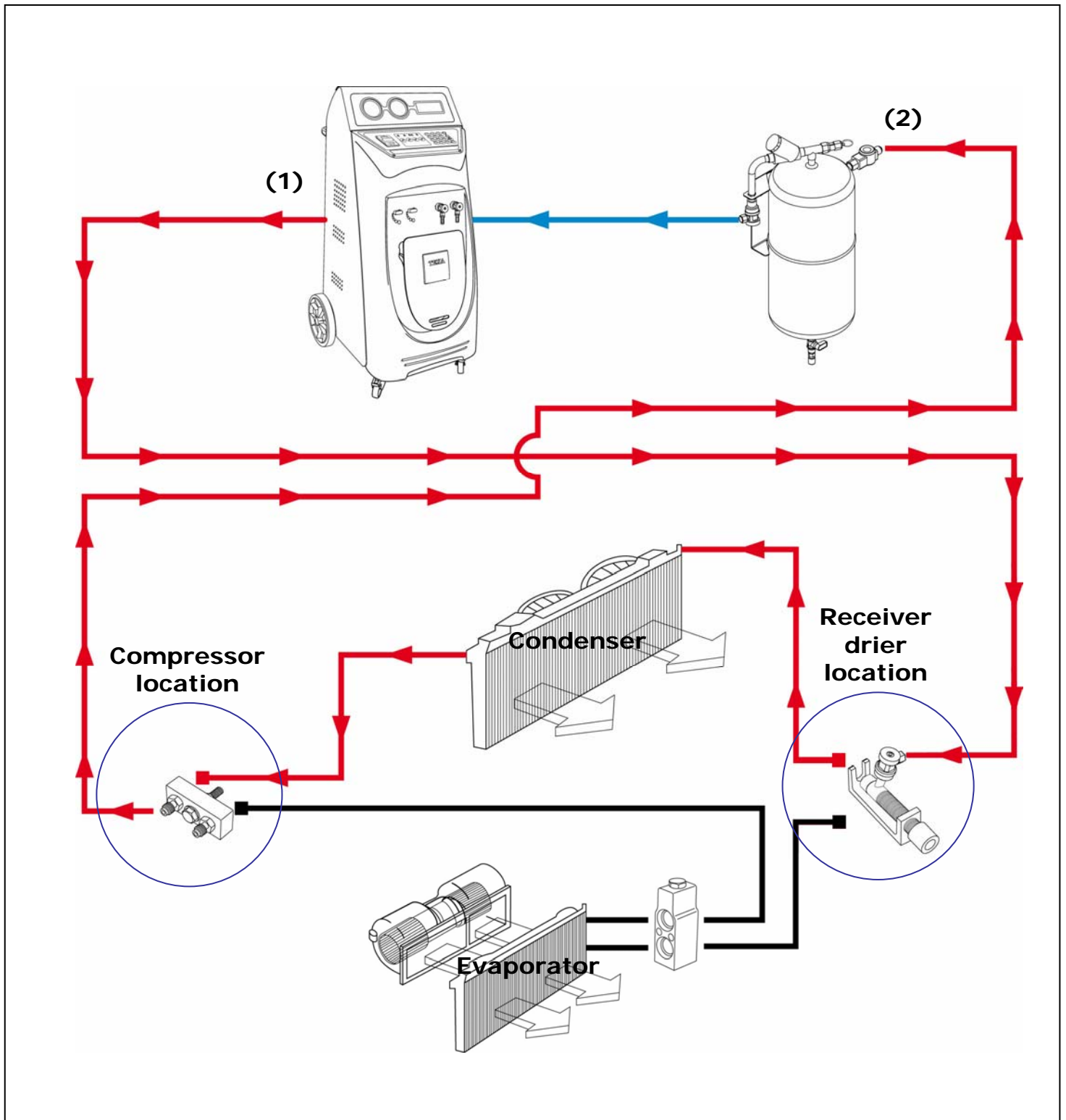



#### 6.5.4 Back-flushing the condenser side

In order to perform the final pass of flushing, reverse the connections to the system. In this situation you will be back-flushing towards the receiver drier location and in the regular flow of the A/C system.

Connect the Konfort unit to system as following :

- (1) Konfort red service hose with HP coupler to the compressor location**
- (2) Canister red service hose 3/8" SAE P/N 3900171 to the receiver drier location**

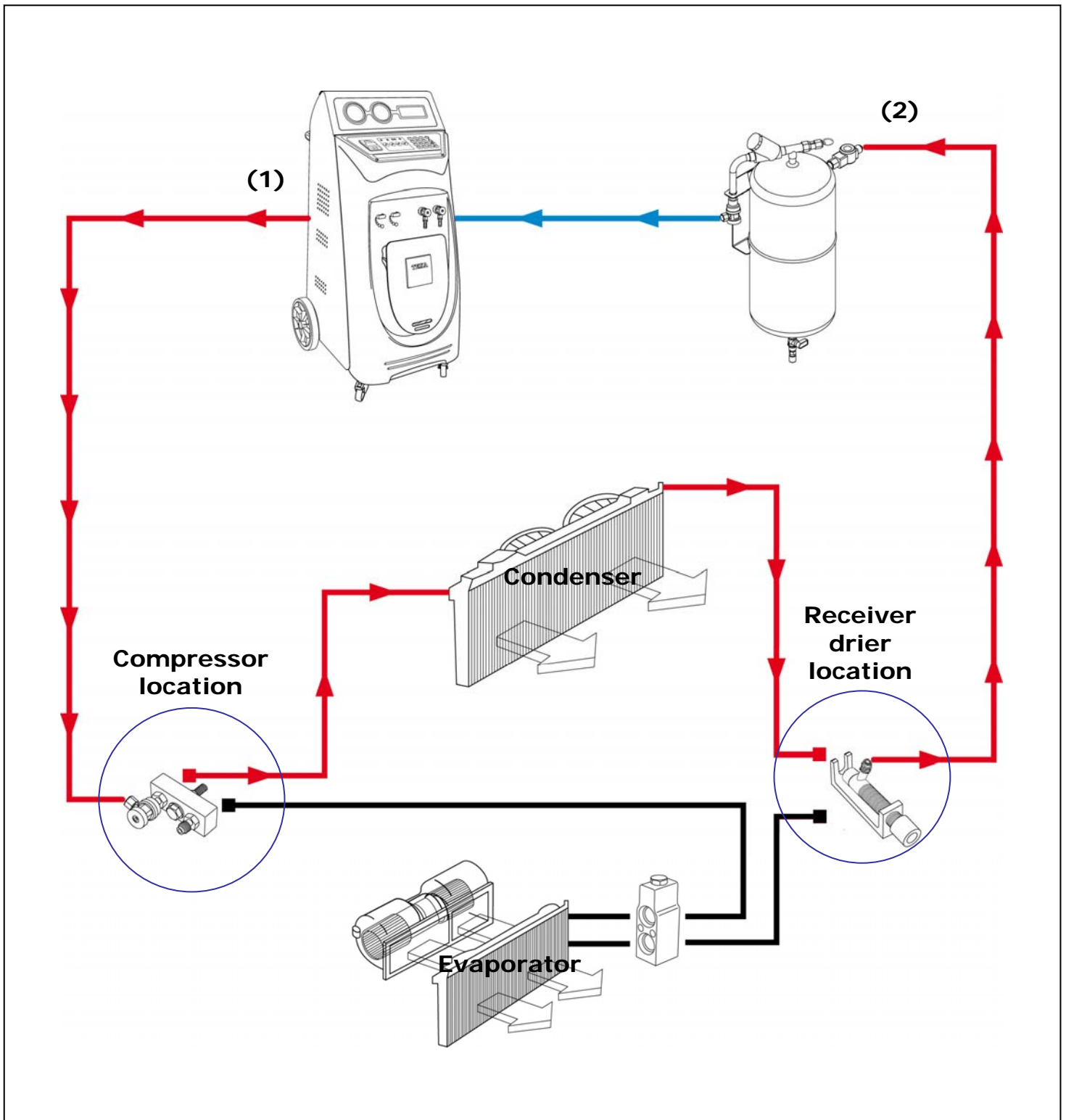

## 6.6 Flushing systems with orifice tube

### 6.6.1 Flushing the evaporator side

In order to prevent particles from the faulty compressor contaminating the rest of the system; start flushing towards the accumulator location in the regular flow of the A/C system.

Connect the Konfort unit to system as following:

- (1) Konfort red service hose with HP coupler to the orifice tube location
- (2) Canister red service hose 3/8" SAE P/N 3900171 to the accumulator location

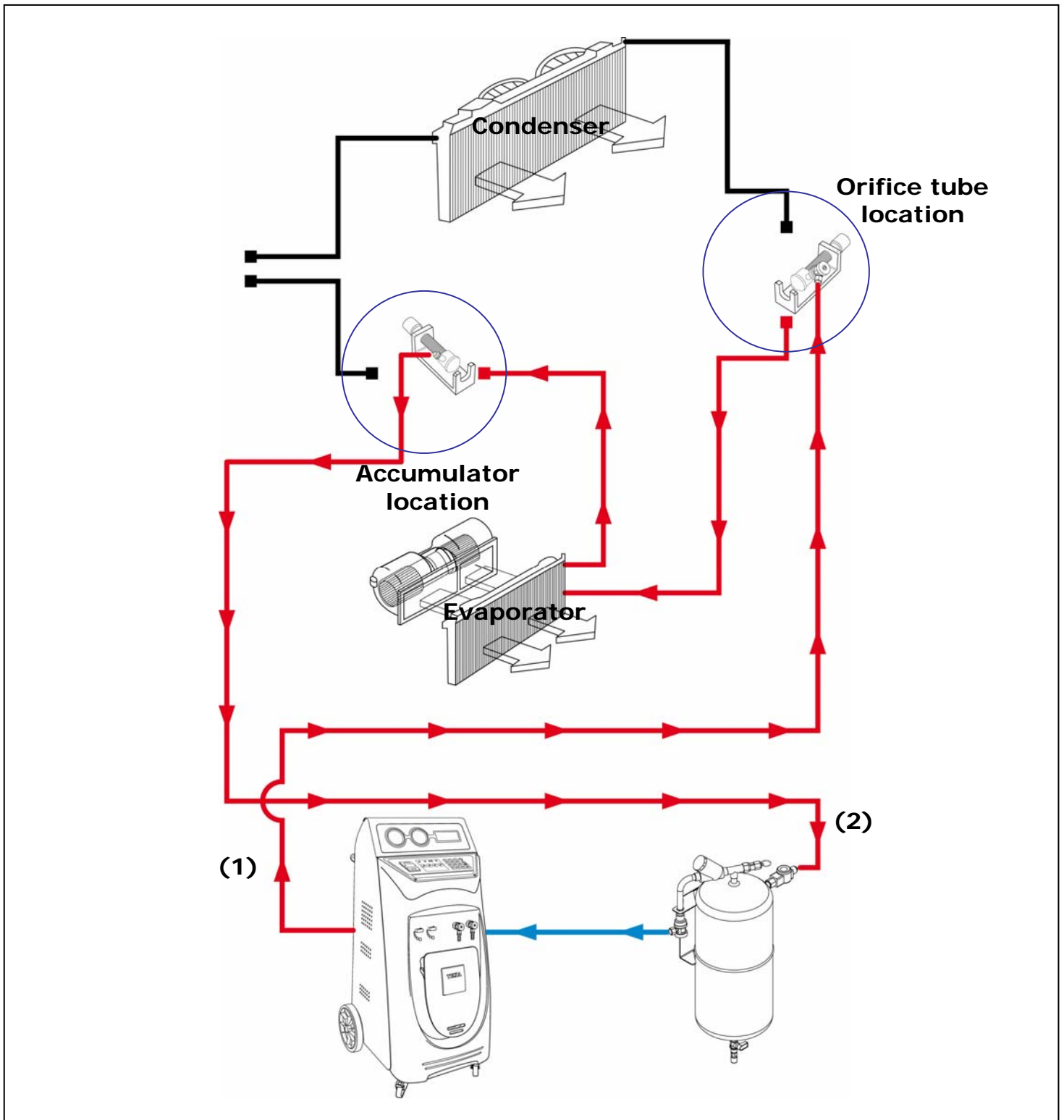



## 6.6.2 Back-flushing the evaporator side

In order to perform the final pass of flushing, reverse the connections to the system. In this situation you will be back-flushing towards the orifice tube location and against the regular flow of the A/C system.

Connect the Konfort unit to system as following:

- (1) Konfort red service hose with HP coupler to the accumulator location**
- (2) Canister red service hose 3/8" SAE P/N 3900171 to the orifice tube location**

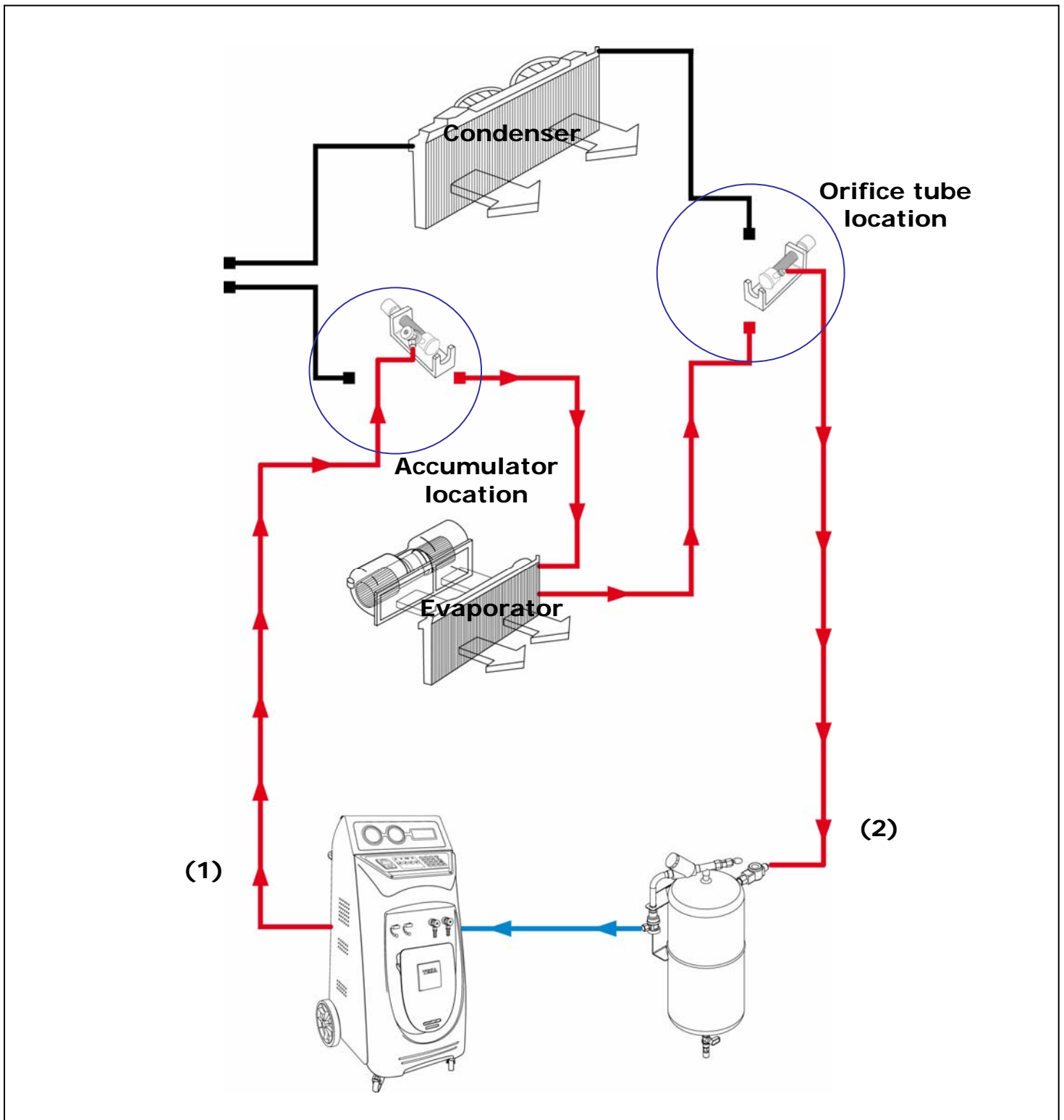

### 6.6.3 Flushing the accumulator-compressor junction

In order to prevent particles from the faulty compressor contaminating the rest of the system; start flushing towards the compressor location in the regular flow of the A/C system.

Connect the Konfort unit to system as following:

- (1) Konfort red service hose with HP coupler to the accumulator location**
- (2) Canister red service hose 3/8" SAE P/N 3900171 to the compressor location**

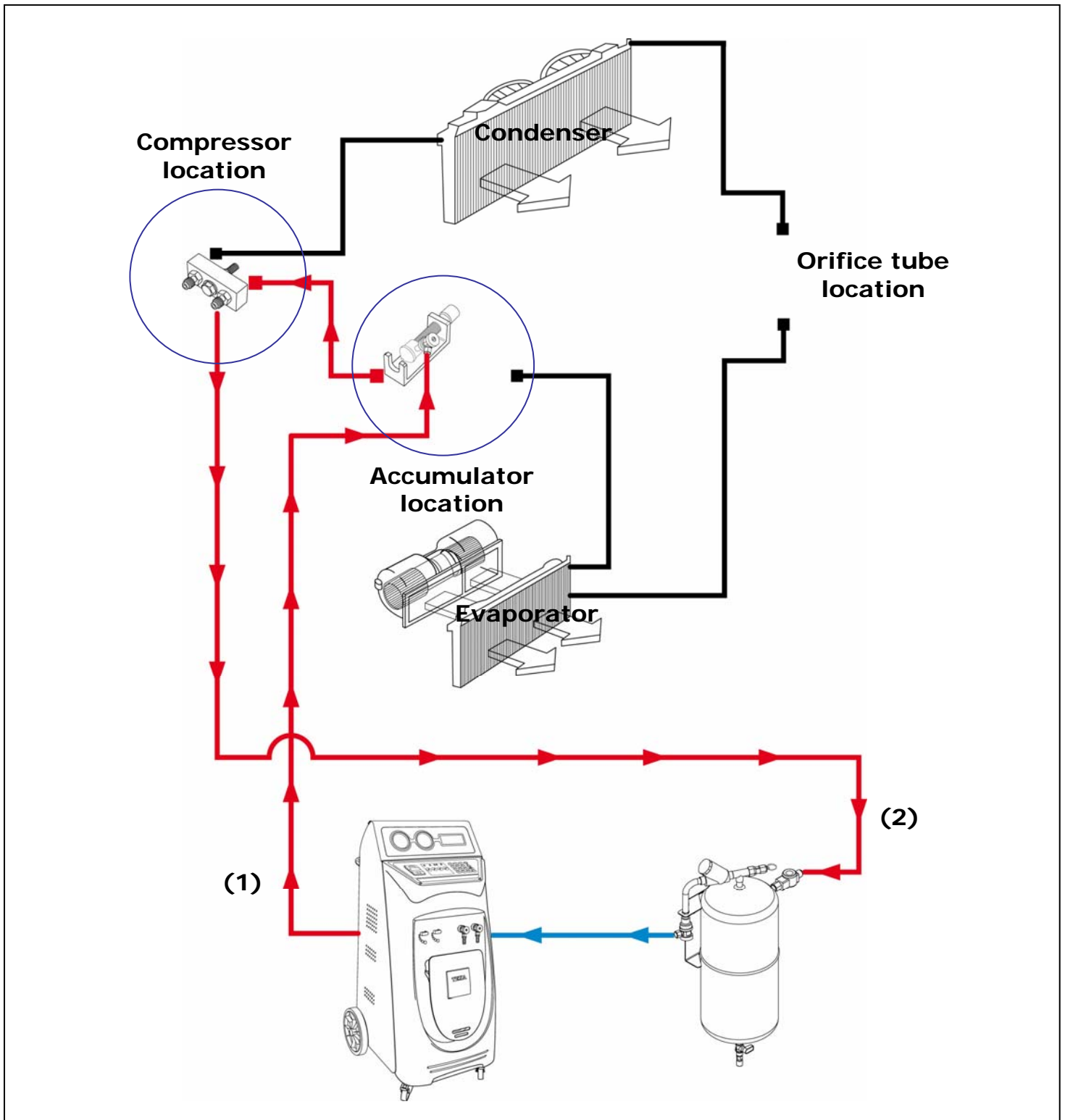

#### 6.6.4 Back-flushing the accumulator-compressor junction

In order to perform the final pass of flushing, reverse the connections to the system. In this situation you will be back-flushing towards the accumulator location and against the regular flow of the A/C system.

Connect the Konfort unit to system as following:

- (1) Konfort red service hose with HP coupler to the compressor location**
- (2) Canister red service hose 3/8" SAE P/N 3900171 to the accumulator location**

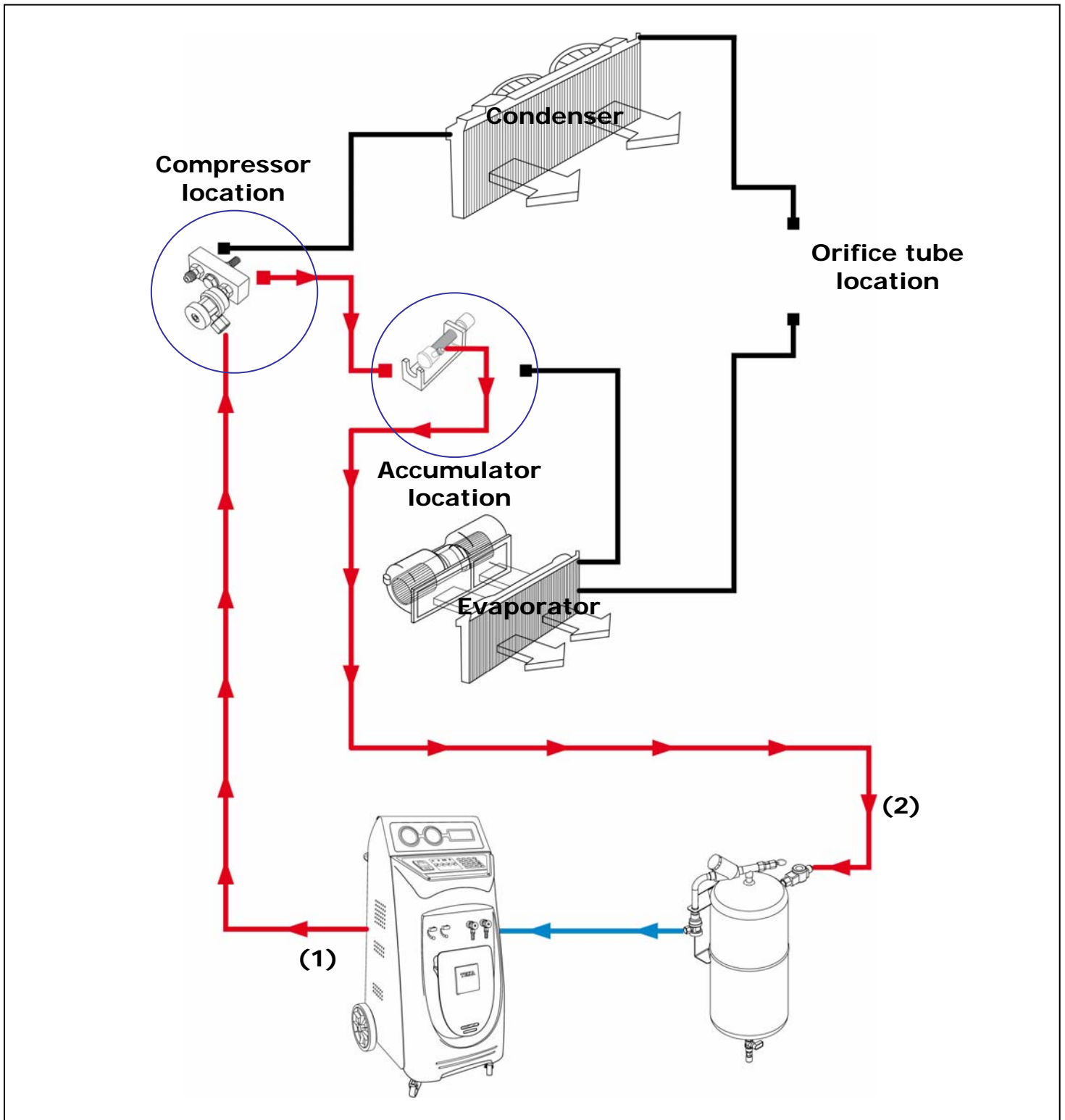

### 6.6.5 Flushing the condenser side

In order to prevent particles from the faulty compressor contaminating the rest of the system; always start flushing towards the compressor against the regular flow of the A/C system.

Connect the Konfort unit to system as following:

- (1) Konfort red service hose with HP coupler to the orifice tube location**
- (2) Canister red service hose 3/8" SAE P/N 3900171 to the compressor location**

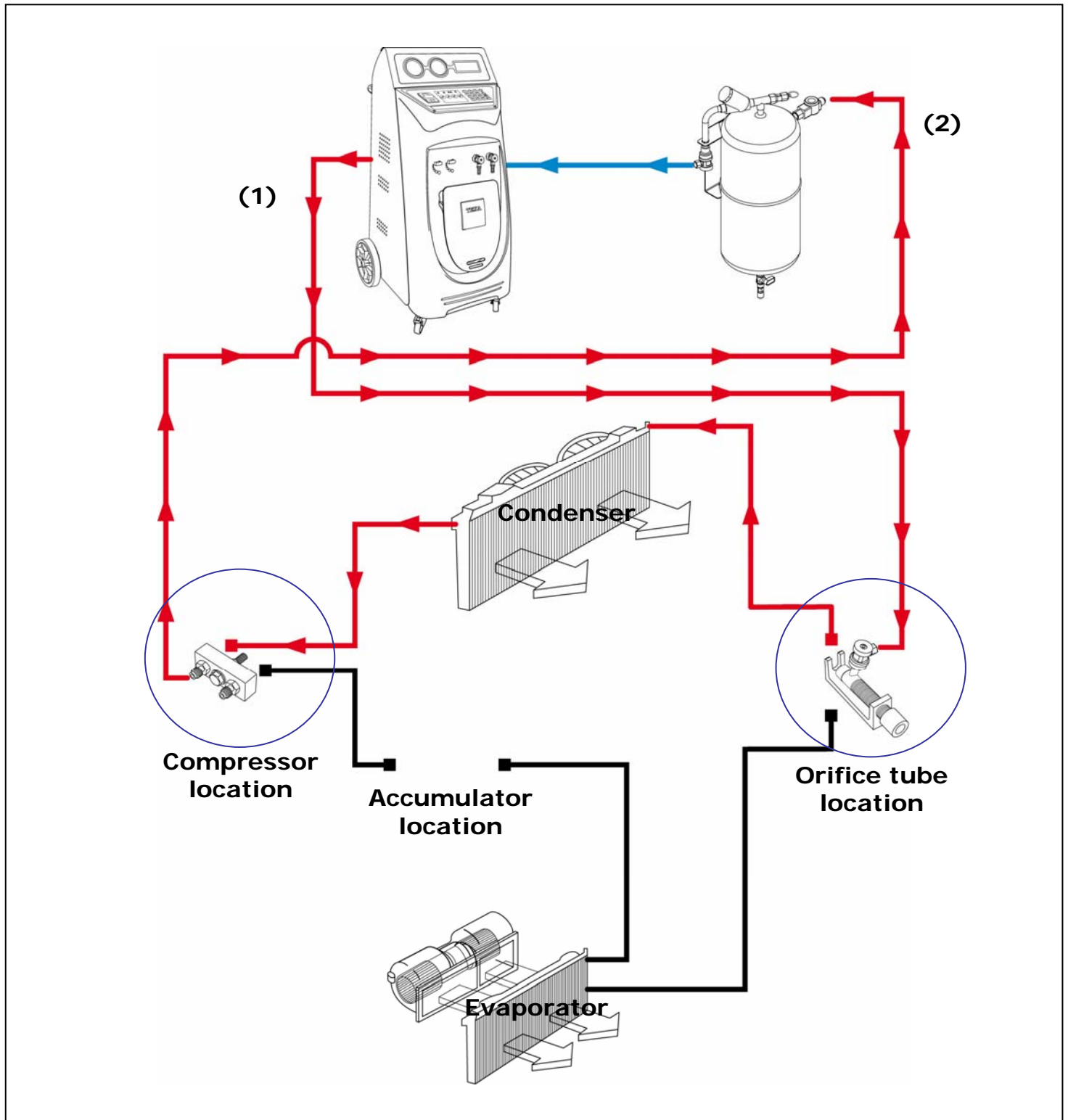

### 6.6.6 Back-flushing the condenser side

In order to perform the final pass of flushing, reverse the connections to the system. In this situation you will be back-flushing towards the orifice tube location and in the regular flow of the A/C system.

Connect the Konfort unit to system as following:

- (1) Konfort red service hose with HP coupler to the compressor location**
- (2) Canister red service hose 3/8" SAE P/N 3900171 to the orifice tube location**

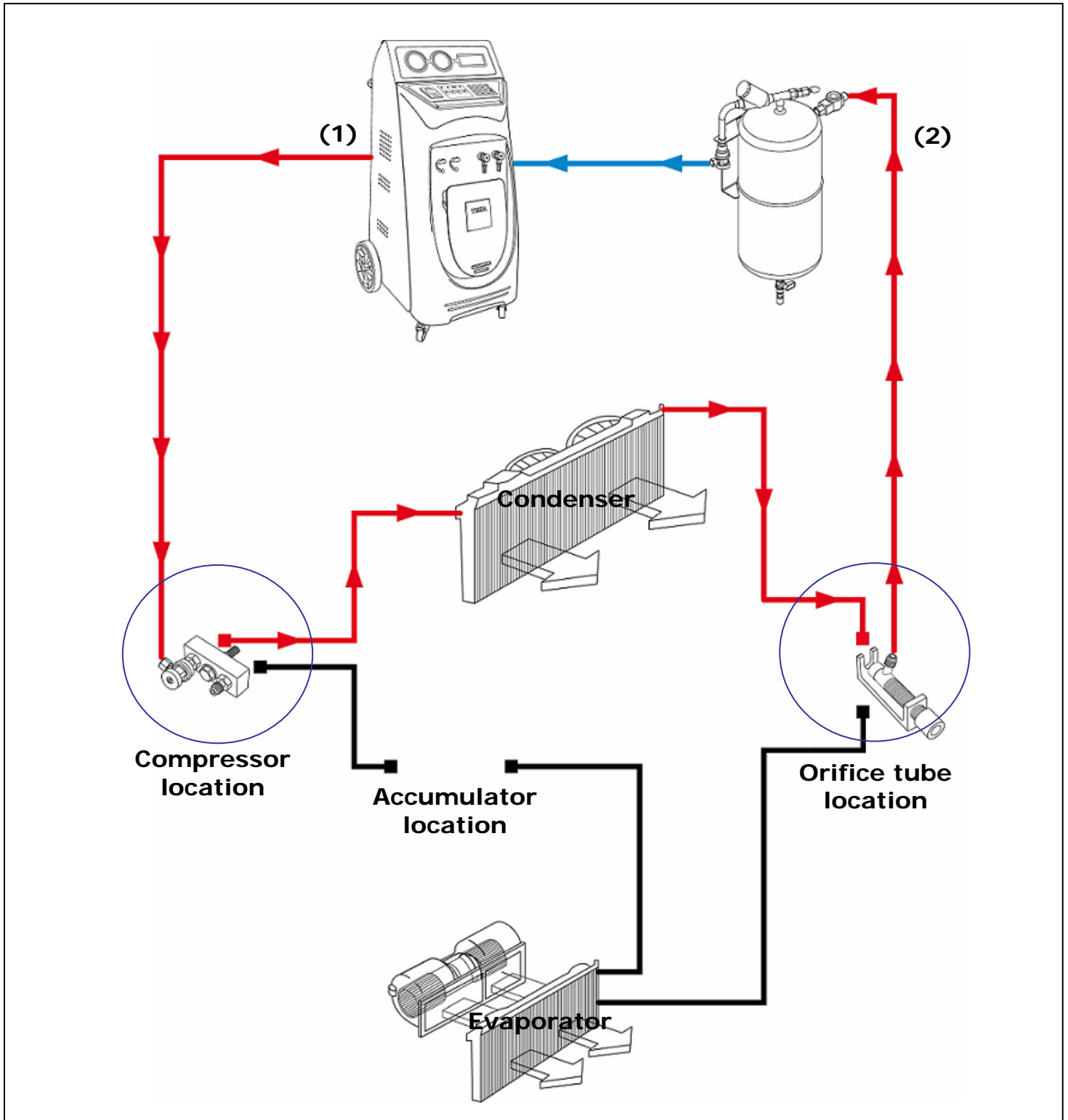

## 6.7 Monitoring flushing process

The flushing canister is equipped with a sight glass allowing to user to monitor the flushing progress and the status of the flushing agent (refrigerant).

This feature also gives to the user the possibility to visualize the nature of the contamination transported by the refrigerant.

There are two possibilities to consider if the flushing process is completed:

- To let the program run by itself, until the selected flushing cycle is fully completed. (single pass or multiple pass modes)
- To monitor the refrigerant passing through the sight glass and decide at which moment the flushing phase can be considerate as completed. When the flushing agent becomes clear, the operator could assume that oil, UV additive and loose particles have been removed from the system. In this case the user can short the process by pressing the **Stop** key.



Flushing canister equipped with sight glass

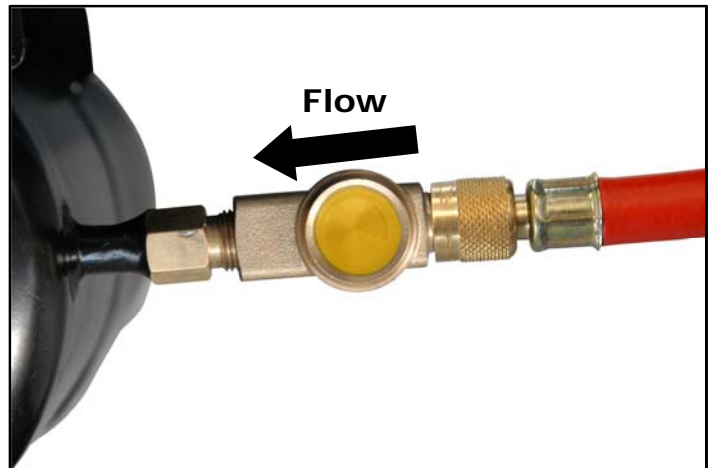

Sight glass showing the flushing agent contaminated with UV additive

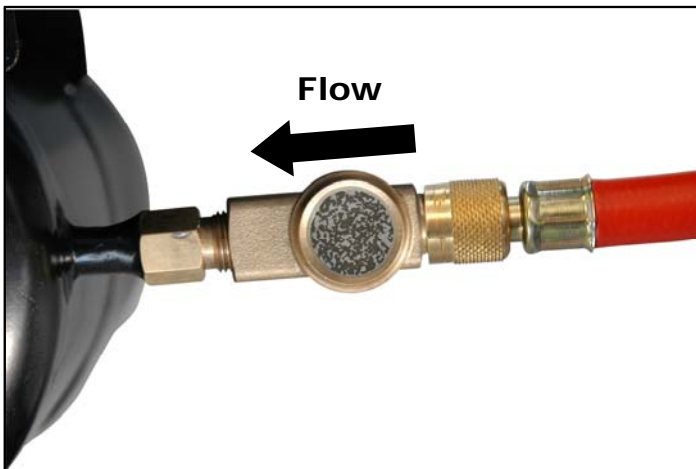

Sight glass showing the flushing agent contaminated with dirty oil or miscellaneous particles

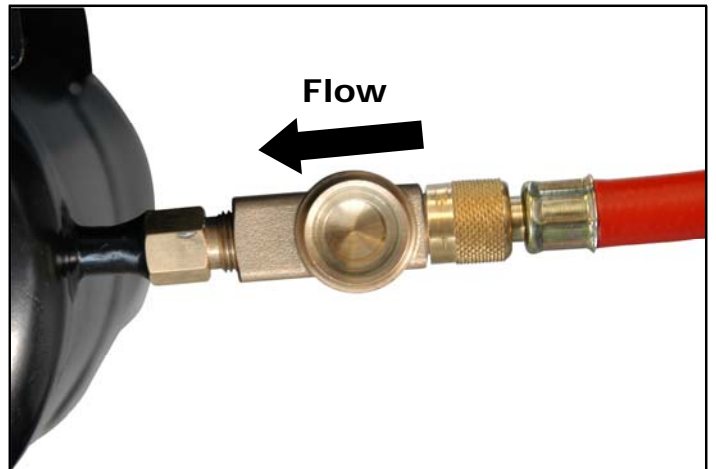

Sight glass showing the flushing agent cleared from any contamination. The A/C system is clean.

## **6.8 After-flushing recommendations**

After having performed a system flushing we are recommending the following steps:

- Replace all O-rings of the system
- Replace the receiver drier or accumulator
- Drain and replace the compressor oil
- Reassemble the complete A/C system
- Pressurize the system with nitrogen and check for leakages
- Bring the system to deep vacuum to remove all moisture
- Inject UV additive in prevention for detecting leakage
- Recharge lubricant and refrigerant within manufacturer specifications
- Verify proper functioning of the system. (Noise, pressure, performances, leak check...)





**NOTE:** If, in Stand-by mode, **INFO** is pressed, the Display shows:

F	W		v	e	r	:		K	6	5	0		0	1		0	1		
D	A	T	A	B	A	S	E		v	e	r	:		X	X				
N	.	x	x	x	x	x				G	G	/	M	M	/	A	A		
I	T		U	K		E	S		P	T		F	R		D	E		D	K

(Here is in example stand-by display of ECK650E)

**Firmware code** (points to K6500101)

**Database code** (points to XX)

**Activation date** (points to GG/MM/AA)

**Serial number** (points to ITUKESPTFRDEDK)

**Available languages (ISO code)** (points to ITUKESPTFRDEDK)

The shown datas identify the equipment version.

### 7.4 Stoppage

Move the Main switch to the OFF position (0) to stop the unit.

**Do not stop the unit by removing the plug.**

### 7.5 Emergency stop

Use the Main Switch for emergency stops. Move the Main Switch to the OFF position (0).

### 7.6 Pressurizing the A/C service station (Only for Konfort 600E series)

The ACKF01 combined with Konfort stations kit is using the liquid refrigerant contained in unit's tank as flushing agent. R134a refrigerant has 4,7 bar pressure at 20°C, which means that the flushing performances are directly depending on tank's internal temperature.

The program of Konfort unit's **600E series** (evolution 2007) is giving the possibility to increase refrigerant pressure up to 9 bars in order to optimize the flushing process.

This function is described below:

#### 7.6.1 Pressurizing Konfort ECK 605E, 610E, 610E BUS, 650

When the unit is in stand-by mode press **UP** or **DOWN**.

The Display shows:

D	A	T	A	B	A	S	E												
A	d	v	a	n	c	e	d		p	r	o	g	r	a	m				
O	t	h	e	r		m	e	n	u	s									◀
D	D	/	M	M	/	Y	Y					H	H	:	M	M	:	S	S

Press **UP** or **DOWN** to select **Other menu**. Press **Enter** to confirm.

The Display shows:

S	e	l	e	c	t		m	e	n	u	.								
V	e	s	s	e	l		f	i	l	l	i	n	g						◀
S	e	r	v	i	c	e													
D	D	/	M	M	/	Y	Y					H	H	:	M	M	:	S	S

Press **UP** or **DOWN** to scroll the display and select **Multi-Recycling**.

The Display shows:

S	e	l	e	c	t		m	e	n	u									
M	u	l	t	i	-	R	e	c	y	c	l	i	n	g					◀
F	l	u	s	h	i	n	g												
D	D	/	M	M	/	Y	Y				H	H	:	M	M	:	S	S	

Press **Enter** to confirm.  
The Display shows:

C	l	o	s	e		L	P	/	H	P		v	a	l	v	e	s		!

Follow instructions and press **Enter** to confirm.  
The Display shows:

P	l	e	a	s	e		w	a	i	t		!							

At this moment the unit verifies the quantity and pressure of the refrigerant available in the unit:

If there isn't enough refrigerant (less than 5 kg), it will stop automatically and show the message "**Not enough refrigerant, add**"

If the pressure is too high in the unit (more than 9 bar), it will stop automatically and show the message "**Warning! Internal vessel overpressure**"

If no problems are detected the program will continue the Multi-Recycling process and the display shows:

M	u	l	t	i	-	R	e	c	y	c	l	i	n	g					
P	r	e	s	s	u	r	e				m	B	.		x	x	x	x	
Q	u	a	n	t	i	t	y				g	.			x	x	x	X	
T	i	m	e								m	i	n	.	M	M	:	S	S

In this phase the Konfort unit performs a multi pass recycling during a maximum time of 10 minutes and the display is indicating:

- The pressure of the refrigerant
- The quantity of refrigerant in the tank
- The time count down in seconds.

You can wait for the end of the count down or press **Stop** to short the process.  
Now the unit is performing a self clearing in order to recover all refrigerant back into the tank.  
The Display shows:

P	l	e	a	s	e		w	a	i	t	!								

At the end, the unit goes automatically back in stand-by mode:

R	e	f	r	i	g	e	r	a	n	t		g	.	X	X	X	X	X	
P	A	G		O	i	l						c	c	.	X	X	X	X	
U	V		A	d	d	i	t	i	v	e		c	c	.	X	X	X	X	
D	D	/	M	M	/	Y	Y					H	H	:	M	M	:	S	S

7.6.2 Pressurizing Konfort ECK 670E  
 When the unit is in stand-by mode press **UP** or **DOWN**.  
 The Display shows:

D	A	T	A	B	A	S	E												
A	d	v	a	n	c	e	d		p	r	o	g	r	a	m				
O	t	h	e	r		m	e	n	u	s									◀
D	D	/	M	M	/	Y	Y					H	H	:	M	M	:	S	S

Press **UP** or **DOWN** to select **Other menu**. Press **Enter** to confirm.  
 The Display shows:

S	e	l	e	c	t		m	e	n	u	.								
V	e	s	s	e	l		f	i	l	l	i	n	g						◀
A	/	C		p	e	r	f	o	r	m	a	n	c	e					
D	D	/	M	M	/	Y	Y					H	H	:	M	M	:	S	S

Press **UP** or **DOWN** to scroll the display and select **Multi-Recycling**.  
 The Display shows:

S	e	l	e	c	t		m	e	n	u									
M	u	l	t	i	-	R	e	c	y	c	l	i	n	g					◀
F	l	u	s	h	i	n	g												
D	D	/	M	M	/	Y	Y					H	H	:	M	M	:	S	S

Press **Enter** to confirm.

The Display shows:

P	l	e	a	s	e		w	a	i	t	!						

At this moment the unit verifies the quantity and pressure of the refrigerant available in the unit:

If there isn't enough refrigerant (less than 5 kg), it will stop automatically and show the message "**Not enough refrigerant, add**"

If the pressure is too high in the unit (more than 9 bar), it will stop automatically and show the message "**Warning! Internal vessel overpressure**"

If no problems are detected the program will continue the Multi-Recycling process and the display shows:

M	u	l	t	i	-	R	e	c	y	c	l	i	n	g			
P	r	e	s	s	u	r	e				m	B	.		x	x	x
Q	u	a	n	t	i	t	y				g	.		x	x	x	
T	i	m	e								m	i	n	.	M	M	
														:	S	S	

In this phase the Konfort unit performs a multi pass recycling during a maximum time of 10 minutes and the display is indicating:

- The pressure of the refrigerant
- The quantity of refrigerant in the tank
- The time count down in seconds.

You can wait for the end of the count down or press **Stop** to short the process.

Now the unit is performing a self clearing in order to recover all refrigerant back into the tank.

The Display shows:

P	l	e	a	s	e		w	a	i	t	!						

At the end, the unit goes automatically back in stand-by mode:

R	e	f	r	i	g	e	r	a	n	t		g	.	X	X	X	X
P	A	G		O	i	l					c	c	.	X	X	X	X
U	V		A	d	d	i	t	i	v	e		c	c	.	X	X	X
D	D	/	M	M	/	Y	Y				H	H	:	M	M	:	S

## 7.7 Flushing cycle Konfort ECK605E / 610E / 610E BUS / 650E

An entire flushing cycle includes the following phases:

- **Vacuuming the system and/or components**
- **Leak testing system and connections**
- **Flushing with liquid refrigerant**
- **Recovery and recycling of the contaminated refrigerant**
- **Separating and draining liquid contamination**

**NOTE:** Perform the instructions shown by the Display.

When the unit is in stand-by mode press **UP** or **DOWN**.

The Display shows:

D	A	T	A	B	A	S	E											
A	d	v	a	n	c	e	d		p	r	o	g	r	a	m			
O	t	h	e	r		m	e	n	u	s							◀	
D	D	/	M	M	/	Y	Y				H	H	:	M	M	:	S	S

Press **UP** or **DOWN** to select **Other menu**. Press **Enter** to confirm.

The Display shows:

S	e	l	e	c	t		m	e	n	u	.							
V	e	s	s	e	l		f	i	l	l	i	n	g					◀
S	e	r	v	i	c	e												
D	D	/	M	M	/	Y	Y				H	H	:	M	M	:	S	S

Press **UP** or **DOWN** to scroll the display and select **Flushing**.

The Display shows:

S	e	l	e	c	t		m	e	n	u								
M	u	l	t	i	-	R	e	c	y	c	l	i	n	g				
F	l	u	s	h	i	n	g											◀
D	D	/	M	M	/	Y	Y				H	H	:	M	M	:	S	S

Press **Enter** to confirm.

The Display shows:

S	i	n	g	l	e		f	l	u	s	h	i	n	g				◀
M	u	l	t	i	p	l	e		f	l	u	s	h	i	n	g		

From this position you have the choice for two different flushing modes. Press **UP** or **DOWN** to select the desired option.

Press **Enter** to confirm.

## INTRODUCTION TO FLUSHING MODES:

**SINGLE FLUSHING:** This program mode is performing one flushing cycle. This configuration is used in case of small contamination and / or simple oil / UV additive removing.

**MULTIPLE FLUSHING:** This program mode is performing tree consecutive flushing cycles. (Except vacuum, this will be performed only one time at the beginning). This configuration is used in case of heavy contamination due to a major failure as compressor damage.

After having selected the required flushing mode,  
The Display shows:

C	o	n	n	e	c	t		H	P		s	e	r	v	i	c	e		
h	o	s	e		t	o		s	y	s	t	e	m						
C	o	n	n	e	c	t		L	P		s	e	r	v	i	c	e		
h	o	s	e		t	o		c	a	n	i	s	t	e	r				

Press **Enter** to confirm.  
The Display shows:

O	p	e	n		L	P	/	H	P		v	a	l	v	e	s	.		
E	N	T	E	R		t	o		c	o	n	f	i	r	m	.			

Press **Enter** to confirm.

The vacuum phase starts automatically...  
The Display shows:

F	l	u	s	h	i	n	g												
V	a	c	u	u	m	.													
T	i	m	e							0	0	:	0	0	:	0	0		
										m	B	.	x	x	x	x			

Vacuum timer and absolute pressure in the system are indicated.  
Default vacuum time is **5 minutes**, but it can be shorted by pressing **UP** / **DOWN**. You can also completely cancel and quit the program by pressing the **Stop** button.

When the vacuum phase is completed, the unit performs a connection leak test:

The Display shows:

F	l	u	s	h	i	n	g												
L	e	a	k		t	e	s	t	.										
										S	e	c	.	x	x	x	x		
										m	B	.	x	x	x	x			

Default leak check time is **240 seconds**, but it can be shorted by pressing **UP** or **DOWN**. You can also cancel and completely quit the program by pressing the **Stop** button.

### LEAKAGE WARNING!

If a leak is detected the following message appears with also the current vacuum value. Verify connection to system and/or components.

L	e	a	k	a	g	e	!												
E	N	T	E	R		t	o		c	o	n	t	i	n	u	e			
										m	B	.	x	x	x	x			

Press **Stop** to cancel and quit the program for fixing a major problem (Important leak). Or press **Enter** to continue if you could solve immediately the issue. (Tightness of one connection).

If no leakage has been detected, the system is ready for flushing.  
The Display shows:

O	p	e	n		o	n	l	y		H	P		v	a	l	v	e		
C	l	o	s	e		L	P		v	a	l	v	e						
E	N	T	E	R		t	o		c	o	n	f	i	r	m	.			

Press **Enter** to confirm.

Now the refrigerant flushing phase is starting.  
The refrigerant flows into the system, and arrives inside the flushing canister.  
The Display shows:

F	l	u	s	h	i	n	g												
A	/	C		s	y	s	t	e	m										
F	i	l	l	i	n	g		p	h	a	s	e							
Q	u	a	n	t	i	t	y					g	.	x	x	x	x		

When flushing phase is completed, the system and or components are full of liquid refrigerant. The canister contains the contaminated refrigerant. You need now to prepare the recovery phase...

The Display shows:

O	p	e	n		o	n	l	y		L	P		v	a	l	v	e		
C	l	o	s	e		H	P			v	a	l	v	e					
E	N	T	E	R		t	o			c	o	n	f	i	r	m	.		

Press **Enter** to confirm.

Now the refrigerant recovery is starting in order to empty the system and the flushing canister. This process can last several minutes.

The Display shows:

F	l	u	s	h	i	n	g												
P	r	e	s	s	u	r	e					m	B	.	x	x	x	x	x
Q	u	a	n	t	i	t	y					g	.	x	x	x	x	x	
■	■	■	■	■	■	■	■	■	■										

When recovery is completed, the unit performs a pressure test, in order to verify if there is residual refrigerant trapped in the system and / or the canister due to icing. Any sudden pressure increase will re-activate the recovery, until system is considerate as perfectly empty.

The Display shows:

F	l	u	s	h	i	n	g												
P	r	e	s	s	u	r	e			i	n	c	r	e	a	s	e		
t	e	s	t	.								m	B	.	-	x	x	x	
												S	e	c	.	x	x	x	x

After the pressure test, the Konfort unit is draining the liquid contamination into to "used oil" bottle. (Compressor oil, UV additive)

The Display shows:

D	r	a	i	n	e	d		o	i	l		c	h	e	c	k	.		
T	i	m	e									S	e	c	.		x	x	
Q	u	a	n	t	i	t	y					c	c	.	x	x	x		

After the count down draining of liquid contamination is completed and quantity is indicated in cc. (No indication of quantity with Konfort ECK605E, 610E & 610E BUS)

The display shows:



O	p	e	n		H	P	/	L	P		v	a	l	v	e	s				
E	N	T	E	R		t	o		c	o	n	f	i	r	m	.				

Press **ENTER** to confirm  
The display shows:

P	l	e	a	s	e		w	a	i	t		!							

During this time Konfort unit is emptying the service hoses.

If the konfort unit is set with a printer, it will issue automatically a print a report and display the following message:

R	e	p	o	r	t		p	r	i	n	t	i	n	g					

When all the cycle is completed,  
the display shows the following message:

E	n	d		f	l	u	s	h	i	n	g								

At the end, the unit goes automatically back in stand-by mode:

R	e	f	r	i	g	e	r	a	n	t		g	.	X	X	X	X	X	
P	A	G		O	i	l						c	c	.	X	X	X	X	
U	V		A	d	d	i	t	i	v	e		c	c	.	X	X	X	X	
D	D	/	M	M	/	Y	Y					H	H	:	M	M	:	S	S

## 7.8 Flushing cycle Konfort ECK670E

An entire flushing cycle includes the following phases:

- **Vacuuming the system and/or components**
- **Leak testing system and connections**
- **Flushing with liquid refrigerant**
- **Recovery and recycling of the contaminated refrigerant**
- **Separating and draining liquid contamination**

**NOTE:** Perform the instructions shown by the Display.

When the unit is in stand-by mode press **UP** or **DOWN**.

The Display shows:

D	A	T	A	B	A	S	E											
A	d	v	a	n	c	e	d		p	r	o	g	r	a	m			
O	t	h	e	r		m	e	n	u	s							◀	
D	D	/	M	M	/	Y	Y				H	H	:	M	M	:	S	S

Press **UP** or **DOWN** to select **Other menu**. Press **Enter** to confirm.

The Display shows:

S	e	l	e	c	t		m	e	n	u	.							
V	e	s	s	e	l		f	i	l	l	i	n	g					◀
A	/	C		p	e	r	f	o	r	m	a	n	c	e				
D	D	/	M	M	/	Y	Y				H	H	:	M	M	:	S	S

Press **UP** or **DOWN** to scroll the display and select **Flushing**.

The Display shows:

S	e	l	e	c	t		m	e	n	u								
M	u	l	t	i	-	R	e	c	y	c	l	i	n	g				
F	l	u	s	h	i	n	g											◀
D	D	/	M	M	/	Y	Y				H	H	:	M	M	:	S	S

Press **Enter** to confirm.

The Display shows:

S	i	n	g	l	e		f	l	u	s	h	i	n	g				◀
M	u	l	t	i	p	l	e		f	l	u	s	h	i	n	g		

From this position you have the choice for two different flushing modes. Press **UP** or **DOWN** to select the desired option.

Press **Enter** to confirm.

## INTRODUCTION TO FLUSHING MODES:

**SINGLE FLUSHING:** This program mode is performing one flushing cycle. This configuration is used in case of small contamination and / or simple oil / UV additive removing.

**MULTIPLE FLUSHING:** This program mode is performing tree consecutive flushing cycles. (Except vacuum, this will be performed only one time at the beginning). This configuration is used in case of heavy contamination due to a major failure as compressor damage.

After having selected the required flushing mode,  
The Display shows:

C	o	n	n	e	c	t		H	P		s	e	r	v	i	c	e		
h	o	s	e		t	o		s	y	s	t	e	m						
C	o	n	n	e	c	t		L	P		s	e	r	v	i	c	e		
h	o	s	e		t	o		c	a	n	i	s	t	e	r				

Press **Enter** to confirm.

The vacuum phase starts automatically...  
the Display shows:

F	l	u	s	h	i	n	g												
V	a	c	u	u	m	.													
T	i	m	e								0	0	:	0	0	:	0	0	
											m	B	.	x	x	x	x		

Vacuum timer and absolute pressure in the system are indicated.  
default vacuum time is **5 minutes**, but it can be shorted by pressing **UP** / **DOWN**. You can also completely cancel and quit the program by pressing the **Stop** button.

When the vacuum phase is completed, the unit performs a connection leak test:

The Display shows:

F	l	u	s	h	i	n	g												
L	e	a	k		t	e	s	t	.										
											S	e	c	.	x	x	x	x	
											m	B	.	x	x	x	x		

Default leak check time is **240 seconds**, but it can be shorted by pressing **UP** or **DOWN**. You can also cancel and completely quit the program by pressing the **Stop** button.

## LEAKAGE WARNING!

If a leak is detected the following message appears with also the current vacuum value. Verify connection to system and/or components.

L	e	a	k	a	g	e	!													
E	N	T	E	R		t	o		c	o	n	t	i	n	u	e				
												m	B	.	x	x	x	x		

Press **Stop** to cancel and quit the program for fixing a major problem (Important leak). Or press **Enter** to continue if you could solve immediately the issue. (Tightness of one connection).

If no leakage has been detected, the refrigerant flushing phase is starting. The refrigerant flows into the system, and arrives inside the flushing canister. The Display shows:

F	l	u	s	h	i	n	g												
A	/	C		s	y	s	t	e	m										
F	i	l	l	i	n	g		p	h	a	s	e							
Q	u	a	n	t	i	t	y					g	.	x	x	x	x	x	

When flushing phase is completed, the system and or components are full of liquid refrigerant. The canister contains the contaminated refrigerant.

Now the refrigerant recovery is automatically starting, in order to empty the system and the flushing canister. This process can last several minutes.

The Display shows:

F	l	u	s	h	i	n	g												
P	r	e	s	s	u	r	e				m	B	.	x	x	x	x	x	
Q	u	a	n	t	i	t	y					g	.	x	x	x	x	x	
■	■	■	■	■	■	■	■	■	■	■									

When recovery is completed, the unit performs a pressure test, in order to verify if there is residual refrigerant trapped in the system and / or the canister due to icing. Any sudden pressure increase will re-activate the recovery, until system is considerate as perfectly empty.

The Display shows:

F	l	u	s	h	i	n	g													
P	r	e	s	s	u	r	e		i	n	c	r	e	a	s	e				
t	e	s	t	.								m	B	.	-	x	x	x		
												S	e	c	.	x	x	x	x	

After the pressure test, the Konfort unit is draining the liquid contamination into to "used oil" bottle. (Compressor oil, UV additive)  
 The Display shows:

D	r	a	i	n	e	d		o	i	l		c	h	e	c	k	.		
T	i	m	e									S	e	c	.		x	x	
Q	u	a	n	t	i	t	y					c	c	.		x	x	x	

After the count down draining of liquid contamination is completed and quantity is indicated in cc.

The display shows:

P	l	e	a	s	e		w	a	i	t	!								

During this time Konfort unit is emptying the service hoses.

If the konfort unit is set with a printer, it will issue automatically a print a report and display the following message:

R	e	p	o	r	t		p	r	i	n	t	i	n	g					

When all the cycle is completed, the display shows the following message:

E	n	d		f	l	u	s	h	i	n	g								

At the end, the unit goes back in stand-by mode:

R	e	f	r	i	g	e	r	a	n	t			g	.	X	X	X	X	X
P	A	G		O	i	l						c	c	.	X	X	X	X	
U	V		A	d	d	i	t	i	v	e			c	c	.	X	X	X	X
D	D	/	M	M	/	Y	Y					H	H	:	M	M	:	S	S

## 7.9 Messages

The following Messages appear in occurrence of alarm, anomaly or request of maintenance.

**The appearance of one of these malfunction/error messages is accompanied by a beeper.**

W	a	r	n	i	n	g	!													
I	n	t	e	r	n	a	l		v	e	s	s	e	l						
O	v	e	r	p	r	e	s	s	u	r	e	.								

The message appears during the recycling phase in case of hot temperature or/and internal vessel at the limit of pressure capacity. Wait 30 min. to cool down and, if the problem persists, contact TEXA S.p.A. or an authorized dealer.

Press **ENTER** three seconds to exit.

W	a	r	n	i	n	g	!														
I	n	t	e	r	n	a	l		v	e	s	s	e	l	.						
F	i	l	l	e	d	.															
P	l	e	a	s	e		w	a	i	t	.										

The message appears during the recovery phase if tank is full. Decrease the refrigerant quantity in the internal vessel.

Press **ENTER** three seconds to exit.

W	a	r	n	i	n	g	!														
P	r	e	s	s	u	r	e		i	n	s	i	d	e		t	h	e			
A	/	C		s	y	s	t	e	m	.											
R	e	c	y	c	l	i	n	g		s	t	a	r	t							

The message appears at the beginning or during the vacuum phase if pressure is detected inside the A/C system.

L	e	a	k	a	g	e	!														
E	n	t	e	r		t	o		c	o	n	t	i	n	u	e	.				
												m	B	.		x	x	x			

The message appears during the leak test phase. Verify A/C system.

In addition, the display shows the vacuum value in mbar.

Press **Enter** to continue or **Stop** to exit.

N	o	t		e	n	o	u	g	h		v	a	c	u	u	m	.		
E	n	t	e	r		t	o		c	o	n	t	i	n	u	e	.		
													m	B	.		x	x	x

The message appears after a **5 mn** vacuum time if the pressure inside the A/C system is not below **50** mB.  
 Press **Enter** to continue or **Stop** to exit.

N	o	t		e	n	o	u	g	h										
R	e	f	r	i	g	e	r	a	n	t	.								
A	d	d	.																

Insufficient quantities to execute the selected phase.  
 Perform "Internal vessel filling" phase (Refer to Konfort units operating manuals).

## 8 MAINTENANCE

### 8.1 Standard maintenance

#### 8.1.1 Konfort units standard maintenance

Konfort units' periodical maintenance intervals are controlled by the software and are indicated by the display when required :

**Filter drier replacement:** every 150 kg. of recovered / recycled refrigerant.

**Vacuum-pump oil replacement:** every 90 hours running time

**NOTE: To perform these operations refer to Konfort units operating manuals.**

#### 8.1.2 Flushing canister filter cleaning / replacement

Time to time clean or replace the stainless steel filter:



- a) Make sure that the canister is empty from any refrigerant. Remove the cap of the mechanical filter assembly, using the appropriated tool.

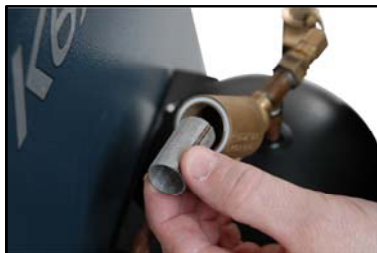

- b) Extract and inspect the filter cartridge. (P/N 3900173)



- c) Clean the filter cartridge with shop-air. You need to replace if it is saturated or damaged.



- d) When finished, proceed with the reverse procedure to re-install the filter cartridge.



### 8.1.3 Flushing canister internal cleaning

Time to time clean the inside of the flushing canister:

**WARNING: Protect your eyes and hands from solid particles being projected.**



- a)** Make sure that the canister is empty from any refrigerant.  
Remove the chromed cap of the tap located at the base of the flushing canister and open the blue valve.

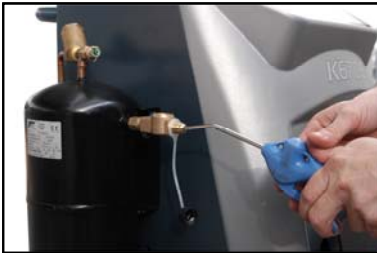

- b)** Flush through the canister inlet with a shop-air gun, contaminations will be pushed out through the tap.  
  
It is suggested to install a little container under the canister, in order to recover the flushed contamination.



- c)** When finished, close the valve of the tap, and re-install the cap.

## 8.2 Periodical operations

In order to guarantee unit's proper functioning, verify periodically, the most exposed to wear and tear components. For this is suggested to check frequently:

Service hoses: must have no cuts, no abrasions or blowing-up

Automatic connectors: must have no wear and tear evident signs, hardening during service and must be rightly connected to the service hoses.

## 8.3 Safety operations

In order to guarantee unit's proper functioning, it is necessary to verify periodically the safety components. The verification period is suggested after 24 months from first activation date. This operation can be made only and exclusively by TEXA and/or authorised TEXA's Service Centre.

## **8.4 Calibration**















It is suggested, at least once per year, to verify the proper functioning of the refrigerant electronic scale and the pressure transducer.



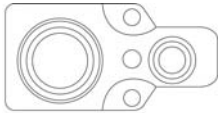

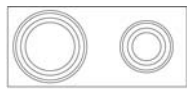
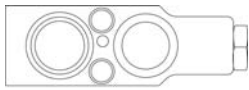

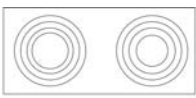

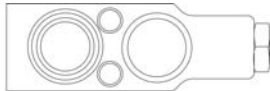
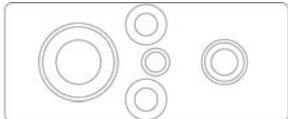
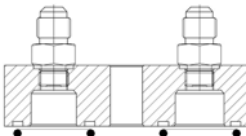
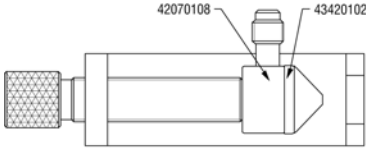
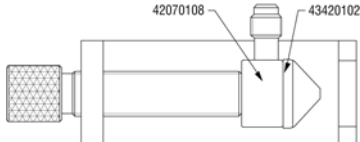
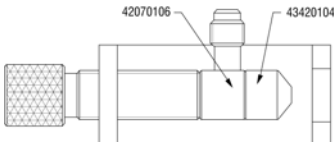
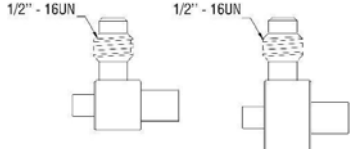
Calibration of these two components is indispensable, and for this reason a specific program has been studied to facilitate the user in this operation.

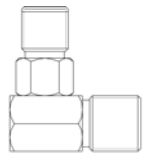
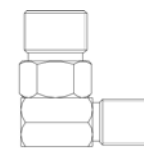
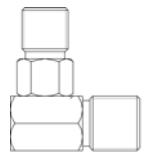
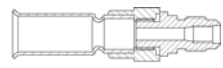
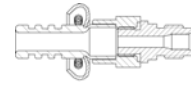
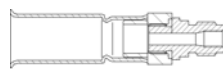
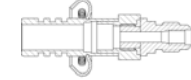
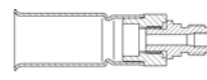
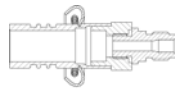
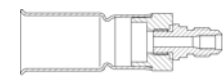
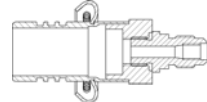
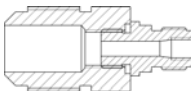
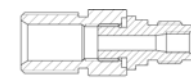
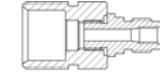
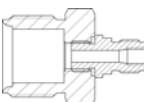
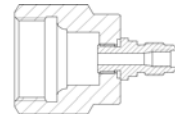
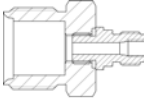
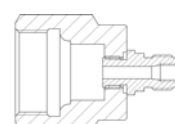
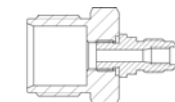
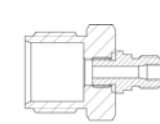
Oil/UV electronic scale calibration is necessary if the load cell or the PC board is replaced or when it seems not working properly. The Oil/UV scale reset is enough to insure proper functioning.

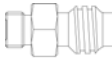
**NOTE: To perform these operations, refer to Konfort units operating manuals.**

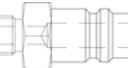
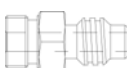
## 9 PARTS LIST & ILLUSTRATIONS

 <p><b>PART NO. 74350486</b> 6.2 Liters flushing canister</p>	 <p><b>PART NO. 3900182</b> Installation kit for Konfort units</p>	 <p><b>PART NO. 3900171</b> Red service hose 3000 mm</p>
 <p><b>PART NO. 3900172</b> Adaptor 1/4" female SAE x 3/8" male</p>	 <p><b>PART NO. 3900173</b> Adaptor 1/4" female SAE x HP R134a</p>	 <p><b>PART NO. 3900173</b> Adaptor 3/8" female SAE x HP R134a</p>
 <p><b>PART NO. 3900175</b> Stainless steel filter</p>	 <p><b>PART NO. 3134</b> Universal flushing adapter set</p>	 <p><b>PART NO.42070010</b> Expansion-Valve Bridge #1</p>
 <p><b>PART NO.42070008</b> Expansion-Valve Bridge #2</p>	 <p><b>PART NO.42070006</b> Expansion-Valve Bridge #3</p>	 <p><b>PART NO.42070012</b> Expansion-Valve Bridge #4</p>
 <p><b>PART NO.42070002</b> Expansion-Valve Bridge #5</p>	 <p><b>PART NO.42070070</b> Expansion-Valve Bridge #6</p>	 <p><b>PART NO.42070016</b> Expansion-Valve Bridge #7</p>
 <p><b>PART NO.42070018</b> Expansion-Valve Bridge #8</p>	 <p><b>PART NO.42070072</b> Expansion-Valve Bridge #9</p>	 <p><b>PART NO.42070004</b> Expansion-Valve Bridge #10</p>
 <p><b>PART NO.42070014</b> Expansion-Valve Bridge #11</p>	 <p><b>PART NO.42070096</b> Compressor Adaptor</p>	 <p><b>PART NO.42070098</b></p>
 <p><b>PART NO.420700100</b></p>	 <p><b>PART NO.420700102</b></p>	 <p><b>42070024</b>      <b>42070026</b></p>

 <p><b>43420102</b>      <b>43420104</b>      <b>43420106</b></p>	 <p><b>PART NO.42070074</b> M16x1.5-&gt;M20X1.5</p>	 <p><b>PART NO.42070076</b> M22R134a-&gt;M16R134a</p>
 <p><b>PART NO.42070078</b> 3/8" R134a-&gt;1/2" R134a</p>	 <p><b>PART NO.42070080</b> 6#Female Springlock</p>	 <p><b>PART NO.42070082</b> 6#Male Springlock</p>
 <p><b>PART NO.42070084</b> 8#Female Springlock</p>	 <p><b>PART NO.42070086</b> 8#Male Springlock</p>	 <p><b>PART NO.42070088</b> 10#Female Springlock</p>
 <p><b>PART NO.42070090</b> 10#Male Springlock</p>	 <p><b>PART NO.42070092</b> 12#Female Springlock</p>	 <p><b>PART NO.42070094</b> 12#Male Springlock</p>
 <p><b>PART NO.42070044</b> 5/8"MF-&gt;7/16"</p>	 <p><b>PART NO.42070046</b> M16 R134a-&gt;7/16"</p>	 <p><b>PART NO.42070048</b> M22 R134a-&gt;7/16"</p>
 <p><b>PART NO.42070050</b> M27x2.0MO-&gt;7/16"</p>	 <p><b>PART NO.42070058</b> M28x1.5MO-&gt;7/16"</p>	 <p><b>PART NO.42070054</b> 1 1/16" - 14UNF -&gt; 7/16"</p>
 <p><b>PART NO.42070056</b> M27x2.0MO-&gt;7/16"</p>	 <p><b>PART NO.42070064</b> 3/4"x7/16" 134a 3/4" R134a 7/16"</p>	 <p><b>PART NO.42070062</b> M27 R134a-&gt;7/16"</p>
 <p><b>PART NO. 42070112</b> M14x1.5 7/16"-20UNF</p>	 <p><b>PART NO.42070066</b> 3/8"-24UNF 1/2"-16</p>	 <p><b>PART NO. 42070110</b> 3/8"-24UNF 7/16"-20UNF</p>
 <p><b>PART NO. 42070022</b> 3/8"-24UNF LP</p>	 <p><b>PART NO. 42070068</b> M14x1.5 7/16"-16</p>	 <p><b>PART NO. 42070020</b> 3/8"-24UNF HP</p>
 <p><b>PART NO.43140800</b> O' ring set (12 pcs)</p>	 <p><b>PART NO.42070104</b> Valve core remover</p>	

For servicing request the detailed spare parts list to TEXA S.p.A. and/or to local Texa authorised Service Centre.

**TEXA USA Inc.**

400 Continental Blv, 6th floor  
El Segundo 90245 CA  
Phone +1.310.426.2394  
Fax +1.310.426.2001  
[www.texausa.com](http://www.texausa.com)

**TEXA Deutschland GmbH**

Bei der Leimengrube, 11  
D-74243 Langenbrettach  
Tel +49 7139 93170  
Fax +49 7139 931717  
[www.texadeutschland.com](http://www.texadeutschland.com)

**TEXA UK Ltd.**

34 Churchill Way  
Lomeshaye Industrial Estate  
Nelson – Lancashire  
BB9 6RT - United Kingdom  
Tel. 01282 606787  
[www.texa.co.uk](http://www.texa.co.uk)

**TEXA France Sarl**

12 Rue Jules Grévy  
42350 La Talaudière FRANCE  
Téléphone 04 77535510  
Fax 04 77534287  
[www.texafrance.fr](http://www.texafrance.fr)

**TEXA Ibérica Diagnosis S.A.**

C/ llevant, 2 (Can Mascaró) - La Palma de Cervelló  
08756 Barcelona  
Tel. +34 93/6535099  
Fax +34 93/6535083  
[www.texaiberica.com](http://www.texaiberica.com)

**TEXA S.p.A.**

Via 1 Maggio, 9  
31050 Monastier di Treviso (TV) – Italy  
Tel. +39 0422/791311  
Fax +39 0422/791300  
[www.texa.it](http://www.texa.it)